



 **BULOVA**
ACCUTRON

**Service
Manual
Series 221**

Table of Contents

MOVEMENT CHARACTERISTICS	1
TO THE WATCHMAKER	2
INFORMATION AND HINTS	
FOR THE ACCUTRON REPAIRMAN	2 & 3
SETTING INSTRUCTIONS	3

SECTION I — BASIC SERVICING PROCEDURES

Opening and Closing Cases	4 & 5
Testing the 221 Power Cell	6
Replacing the 221 Power Cell	7
Regulation	8 & 9

SECTION II — GENERAL INFORMATION

Special Tools, Equipment and Lubricants	10, 11, 12
Terminology	13
Checking Train Freedom	13
Diagnostic Chart	14 & 15
Special Points for the ACCUTRON Repairman	16
Electrical Disconnect System: Inspection and Adjustment	17
Testing the Electronic Circuit	18, 19, 20
Indexing Mechanism: Inspection and	
Adjustment (Phasing)	21, 22, 23

SECTION III — DISASSEMBLY

Remove Dial Assembly	24
Remove Coil Assemblies	24
Disengage Index and Pawl Fingers	25
Remove Tuning Fork	25

SECTION IV — SERVICING

26

SECTION V — LUBRICATION AND REASSEMBLY

Remove Second Wheel	27
Remove Train Bridge and Train Wheels	27
Oil Cap Jewels and Fourth Wheel	28
Replace Second Wheel Assembly	28
Replace Tuning Fork	29
Replace Coil Assemblies	29
Check Coil Clearance	30
Pre-Test Tuning Fork and Coil Assemblies	30
Lubricate Train and Setting Mechanism	31
Phasing	31
Replace Dial and Hands	31
Check Phasing and Regulation	31

SECTION VI — ADDITIONAL MAINTENANCE — DISASSEMBLY AND REASSEMBLY

Dial Assembly	32
Setting Mechanism	33
Pawl Bridge Assembly	34

SECTION VII — CHECKING THE CASED MOVEMENT

35

SECTION VIII — PARTS LIST

Parts List for Series 221	36
---------------------------------	----

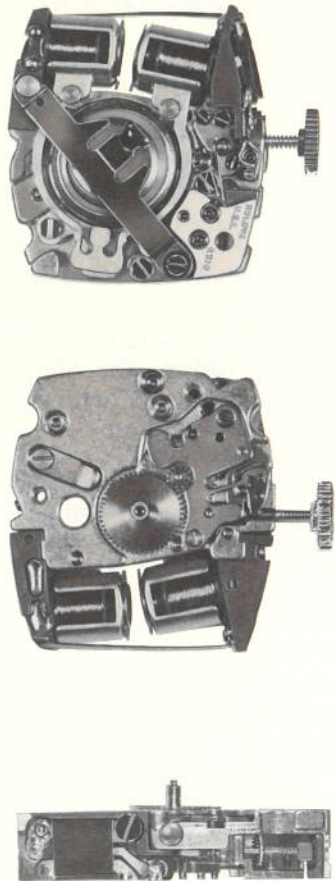

Fig. 1

Movement Characteristics

- Tuning Fork — 17½ mm.
- Frequency — 440 Hz. (cycles per second). This is the tone of "A".
- Movement Dimensions — Tonneau Shape
 - 7½ x 8½ lingne
 - 19.4 mm. (.763") long x 17.4 mm. (.685") wide
 - 4 mm. thick without battery
- Index Wheel — Diameter 2.15 mm. 270 teeth
- Electromagnetic Coils — two, with approximately 8,100 turns of insulated copper wire on each.
- Electronic Components — Hybrid integrated circuit
- Electrical Disconnect System — When the stem is pulled out, the watch stops due to a unique electrical disconnect system, thereby, allowing for storage in this position. The same cell will operate the watch for a full year after this storage period.
- Jewels — 14
- Accuracy — Warranted to keep time within one minute per month.
- Power Source — A special mercury oxide power cell — approximately 1.35 volts. Identified as "ACCUTRON 221".

FEATURES

- This is the first American made Tuning Fork Watch to be marketed in Ladies Conventional Size Cases, Pendant Styles and Selected Mens Styles.

PATENT NOTICE

The ACCUTRON® timepiece is manufactured by Bulova Watch Company, Inc., under issued patents as well as pending patent applications, including the following patents:

U.S.	2,971,323; 3,162,005; Re. 26,209; 3,257,794; 3,221,190; 3,262,259; Re. 26,322; 3,421,310; 3,421,311; 3,628,323;
Canada	609,691; 764,176; 756,819; 685,419.
France	1,491,231; 1,473,353; 1,322,145; 70.04247; 70.40618.
Great Britain	955,559; 1,064,230; 1,074,104; 1,269,885.
Switzerland	353,811; 518,584; 528,771.
Italy	683,351; 888,693; 916,127.
The Netherlands	228,637.
Mexico	109,120.
Japan	301,465.

"Accutron", "Bulova", "Watchmaster" and "⌚" are registered trademarks of the Bulova Watch Company, Inc.

All information contained in this booklet is based on the latest product information available at the time of printing. The right is reserved to make changes at any time without notice.

©1976 Bulova Watch Company, Inc. All Rights Reserved.

Bulova Watch Company, Inc.
62-10 Woodside Ave.
Woodside, N.Y. 11377

Bulova Watch Company, Ltd.
105 Bartley Drive
Toronto, Ontario, Canada M4A 1C8

Bulova Watch Company, Inc.
44 Faubourg DuJura
2500 Bienne 4, Switzerland

To The Watchmaker

This manual provides complete service and repair information for the Series 221 ACCUTRON® movement.

Should you already be familiar with the proper repair procedures necessary for the Series 214, 218 and 230, you will need only become familiar with the following innovative designs unique to the 221:

- A. WORM GEAR ARRANGEMENT
- B. ELECTRICAL DISCONNECT SYSTEM
- C. FLOATING CANNON PINION
- D. SPRING MOUNTING OF THE MOVEMENT IN ITS CASE

None of the above will present any difficulties. With the aid of this manual and the use of proper equipment, servicing of the 221 will be quick and profitable. Follow the detailed step-by-step procedures outlined.

Like previous ACCUTRON watches, the 221 requires servicing **ONLY AS NECESSARY**. A few minutes spent analyzing the reasons **WHY** the movement requires servicing will allow you to deal directly with the problem area. The troubleshooting charts on Pages 14 and 15 will provide solutions to almost all of the problems you may encounter. The first step in using these procedures is to establish the symptoms of the trouble. In many instances, this information can be obtained only from the customer. Therefore, **WHENEVER POSSIBLE FIND OUT EXACTLY WHAT THE CUSTOMER'S COMPLAINT IS BEFORE YOU ATTEMPT CORRECTION**.

Should cleaning be required, the repairman need only loosen or remove seven screws. A floating cannon pinion design permits the hands, dial, dial washer, hour wheel and cannon pinion to be removed as a unit. Once the coil assemblies and tuning fork have been removed, the movement is ready for ultrasonic cleaning.

This manual includes a "Pre-test" section within the reassembly procedures. Pre-testing of the coils and checking of the rate of the tuning fork, prior to phasing, confirms that the electronic portion of the watch is functioning correctly.

No effort has been spared to provide the watchmaker with as serviceable a product as possible. Coil assemblies can be replaced without removing the tuning fork or disturbing the indexing mechanism. The movement can be completely torn down and reassembled in a relatively short time. Years of experience with the Series 214, 218 and 230 have led to the development of the Series 221 ACCUTRON movement.

Information and Hints For The Accutron Repairman

EQUIPMENT

Do not attempt to service the ACCUTRON movement (other than regulation or Power Cell replacement) without a suitable microscope and the ACCUTRON Test Set, contained in the repair kit.

EXCHANGING MOVEMENTS TO CORRECT A PROBLEM

BULOVA does not recommend exchange of movements to solve a customer's problem. The ACCUTRON movement, unprotected by the case, can be readily damaged or its functioning seriously disturbed. The repairman who lacks the necessary equipment and knowledge to diagnose and repair the trouble with an ACCUTRON movement can rarely satisfy the customer by switching movements. This usually results in two problem movements and one **VERY** dissatisfied customer.

CLEANING

The practice of cleaning a watch, as a routine part of nearly every repair, results from the watchmaker's knowledge that optimum performance and reliability can be expected only when lubrication is fresh. The performance of ACCUTRON is relatively unaffected by the condition of the lubrication. Thus, cleaning will not usually be required to restore an ACCUTRON timepiece to proper operating condition.

OILING

The instruction to oil sparingly is repeated here for emphasis. Flooding the various bearings can result in oil running on to the teeth of the index wheel. In this instance, oil attracts and holds any dirt or foreign matter in the case, which may then interfere with proper operation of the indexing mechanism. This trouble is rarely experienced if the bearings are oiled properly.

REMOVING AND REPLACING THE TUNING FORK

The tuning fork may be loosened during removal by inserting a screwdriver or other tool into the recess shown in Fig. 64, Pg. 25. This practice will not "bruise" the tines, if done properly. Never touch any part of the tuning fork with metal tools any place other than at the base. Use tweezers to pick up the tuning fork, by inserting one tweezer blade in one of the screw holes in the tuning fork base.

INDEX WHEEL ENDSHAKE

Insufficient endshake of the index wheel pinion in its bearings can cause the index wheel to fail to "draw" back reliably after each operation of the indexing mechanism. This results in the timepiece gaining excessively. While this condition is rare, it is good practice, whenever checking the movement, to perform the simple check which will detect it. With the movement running on the Movement Holder, attached to the Test Set, press on the index upper endstone cap jewel with pegwood. If there is no endshake, the slightest pressure on the cap jewel will cause a significant increase in the meter reading.

REMOVAL OF LINT

Attention must be paid to the removal of any lint particles in the movement. Whenever working on the movement, be it for overhaul, Power Cell replacement, or regulation, be sure that the work area is free of lint.

Inspection of the movement prior to casing is strongly recommended. Remove any lint present.

ELECTRICAL DISCONNECT SYSTEM

This system allows for storage of the movement with the Power Cell installed. When the stem is pulled to the "setting" position, the movement consumes only one-third ($\frac{1}{3}$) microampere of current. With a fresh Power Cell installed, the watch may be stored for a year and still operate a full year when the stem is pushed "in" to the run position.

Setting Instructions

1. Pull crown "out".
2. Turn hands (either direction) until minute hand is at least five minutes ahead of desired minute marker. THEN TURN HAND BACKWARD TO THIS MARKER.
3. Push crown "in" without turning.
4. As with any watch without a second hand, it is good practice to listen to make certain that the movement is running. IF NECESSARY, TAP THE CASE LIGHTLY AT THE "3" OR "9" TO START THE TUNING FORK VIBRATING.

SECTION I — BASIC SERVICING PROCEDURES

Snap Back Cases

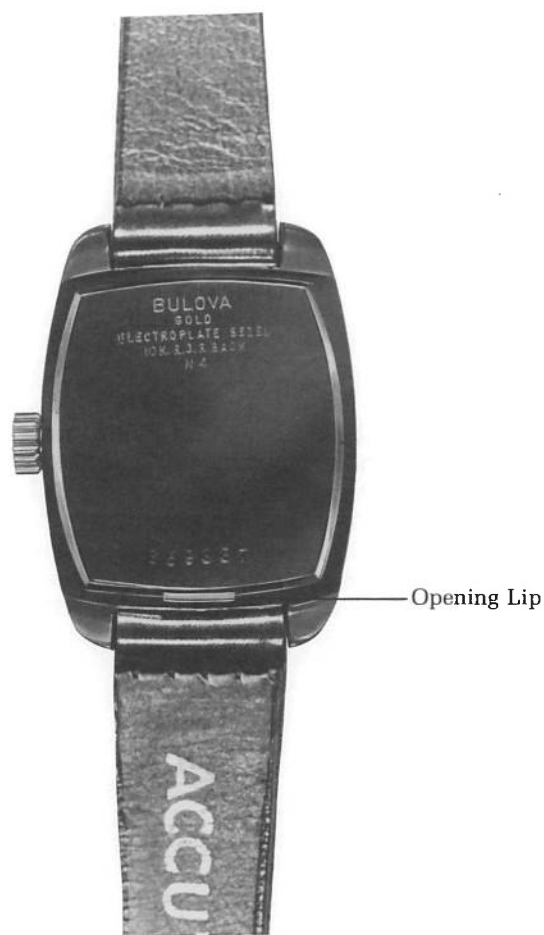

Fig. 2

Opening and Closing Cases

HOW TO OPEN SNAP BACK CASES

CAUTION: Clean work area before opening case to prevent magnetic particles from being attracted to tuning fork magnets.

TOOLS REQUIRED: *Case Knife
*Plastic Bag
*Lint-free Cloth

1. Clean back of case and wipe away any accumulated material to prevent dirt from entering when back is removed.
2. Pull stem to "setting position".
3. Fold a small piece of plastic over a case knife and, with the plastic between the blade and the back, press knife under opening lip. (Fig. 2)
4. Rock carefully until back snaps off.
5. For regulation and Power Cell replacement:
Remove movement from case back and place **IN THE BEZEL**.

HOW TO CLOSE SNAP BACK CASES

1. Place movement **IN CASE BACK**.
2. Pull crown to "setting position".
3. Snap bezel and case together by applying pressure **FIRST** on the 12 o'clock side, **THEN** on the 6 o'clock side. Case will snap closed.

Note: After setting, push crown **IN**. Listen for tuning fork hum to make certain watch is running, or place watch on Vibrograf pick-up to check if tuning fork is vibrating. If no hum is heard, tap case lightly at 9 o'clock to start tuning fork vibrating.

HOW TO OPEN SCREW BACK CASES

Tools required: *Black Plastic Case Wrench or Metal "L" Wrench
*Lint-free Cloth

1. Clean back of case and wipe away any accumulated material from around locking ring to prevent dirt from entering when back is removed.
2. Unscrew and remove locking ring and case back using case wrench.
3. For regulation and Power Cell replacement:
Movement can be left in the case bezel.

HOW TO CLOSE SCREW BACK CASES

1. To reassemble, check to make certain movement and gasket are properly seated, and locating tab is properly positioned.
2. Pull crown to "setting position".
3. Screw locking ring firmly in place using case wrench.

Note: After setting, push crown IN. Listen for tuning fork hum to make certain watch is running, or place watch on Vibrograf pick-up to check if tuning fork is vibrating. If no hum is heard, tap case lightly at 9 o'clock to start tuning fork vibrating.

Screw Back Cases

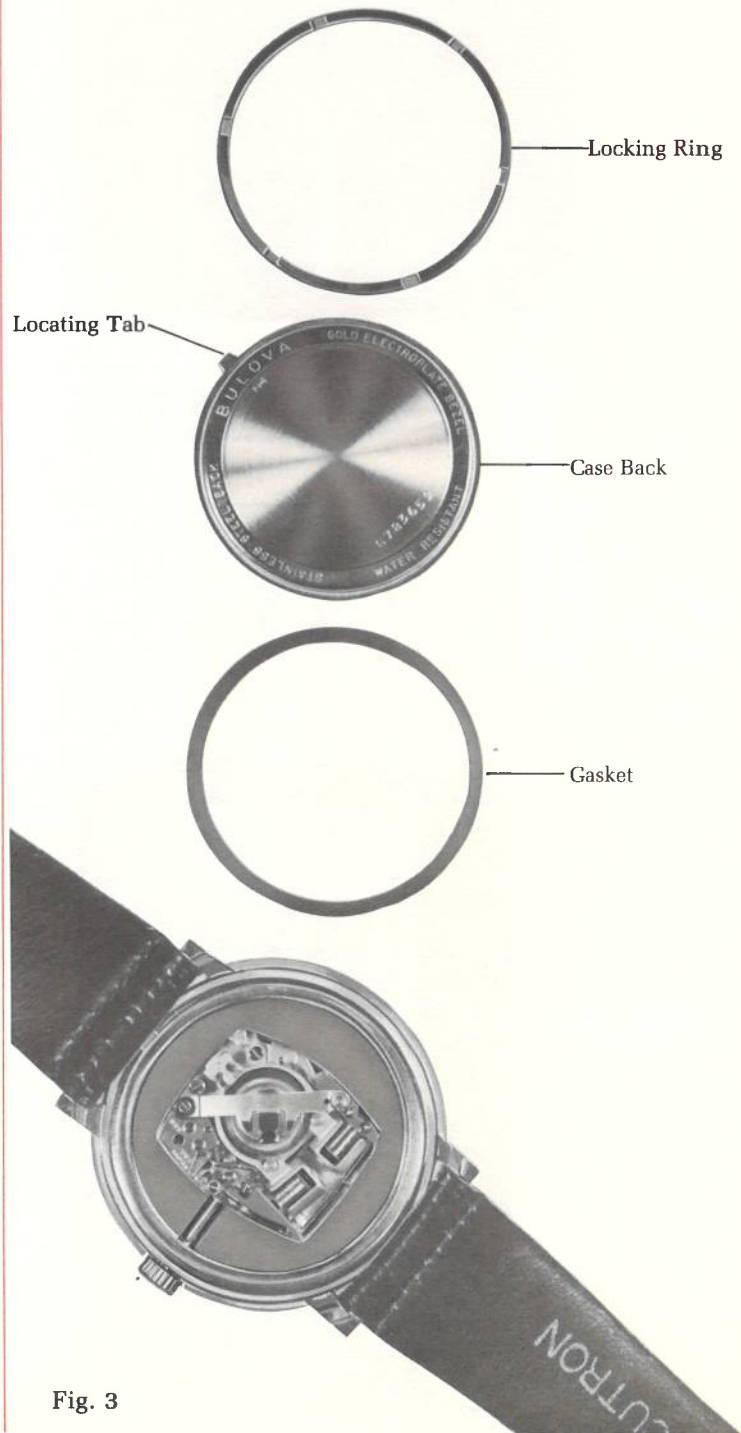

Fig. 3

Testing The 221 Power Cell

USING THE ACCUTRON TEST SET

1. Place Power Cell with **PRINTED SIDE DOWN** in nest of Test Set.
2. Turn rotary switch on Test Set to "Check Power Cell" position.
3. Read Power Cell voltage on right-hand scale. The voltage reading should be in the "OK" area of scale (1.25 to 1.45 volts).

Note: Poor electrical contact between Power Cell and Test Set will cause either a "O" reading or a **wavering** indication of cell voltage. It can be readily avoided by making certain that the Power Cell surfaces and contacting points of the Test Set nest and clip are clean. Rubbing or twisting the cell between the contacts while checking voltage is good practice. A wavering reading of voltage is always an indication of poor contact, not an indication of a bad cell. Testing should always be done with the authorized ACCUTRON Test Set or with a high-resistance voltmeter (having not less than 10,000 OHMS per volt sensitivity).

Caution: Never use substitute cells in place of genuine "ACCUTRON 221" Power Cells. Though other cells may look like the "ACCUTRON 221", they may not reliably operate the timepiece and may, in some instances, seriously damage the movement. Any damage to the watch caused by a non-genuine Power Cell is not covered by our warranty.

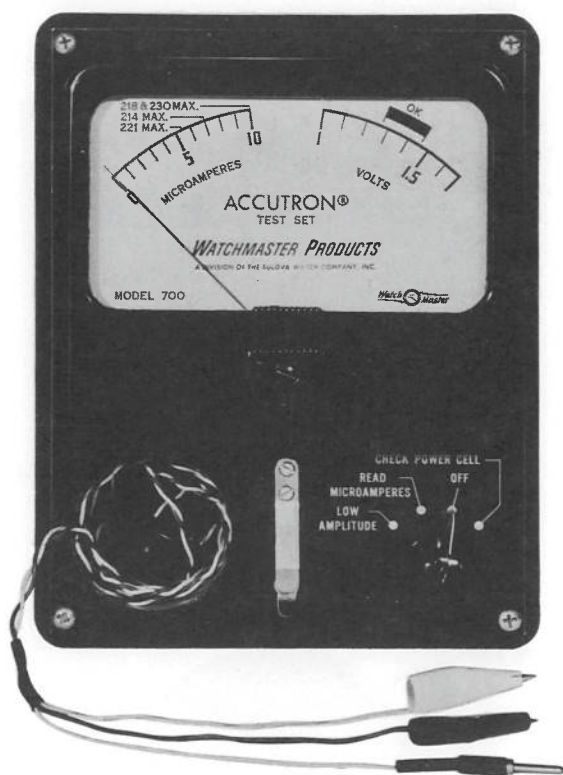

Fig. 4

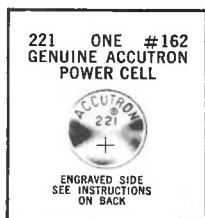

Fig. 5

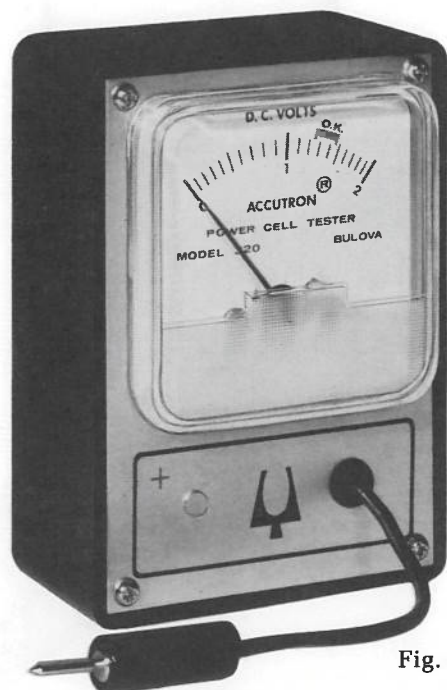

Fig. 6

USING THE ACCUTRON POWER CELL TESTER

1. Place the Power Cell with **PRINTED SIDE DOWN** onto the terminal marked ("+") on the Power Cell Tester.
2. Place the probe, at the end of the lead, on the negative (non-printed) side of the Power Cell.
3. The voltage reading should be in the "OK" area of the scale (1.25 to 1.45 volts).

Replacing The 221 Power Cell

Power Cell required: "ACCUTRON 221"

Tools required: *Power Cell Tester
*Lint-free Cloth
*Pointed Tool

1. Before installing, check the new cell (Page 6). Reading should be in the "OK" area of scale (1.25 to 1.45 volts).
2. Do **NOT** loosen any screws. Insert a pointed tool in the hole near the end of the cell strap. Applying a light downward pressure, swing cell strap away from hold-down post. (Fig. 7)
3. Pull stem to "setting position". Grasp crown and remove movement from bezel. Invert movement and cell will fall out.
4. Replace movement in **case bezel**.
5. Inspect cell compartment and underside of strap for foreign material. Clean, if necessary, to assure a good electrical contact. **DO NOT SCRAPE AWAY ANY OF THE INSULATION.**
6. Insert a fresh Power Cell with words "ACCUTRON 221" **FACING DOWN**.
7. Reposition strap into groove of Insulator #610. Applying a light downward pressure in the hole near end of strap, swing strap into hold-down post.
8. See Pages 4 and 5 for closing case.

CAUTION: Clean work area before opening case to prevent magnetic particles from being attracted to tuning fork magnets.

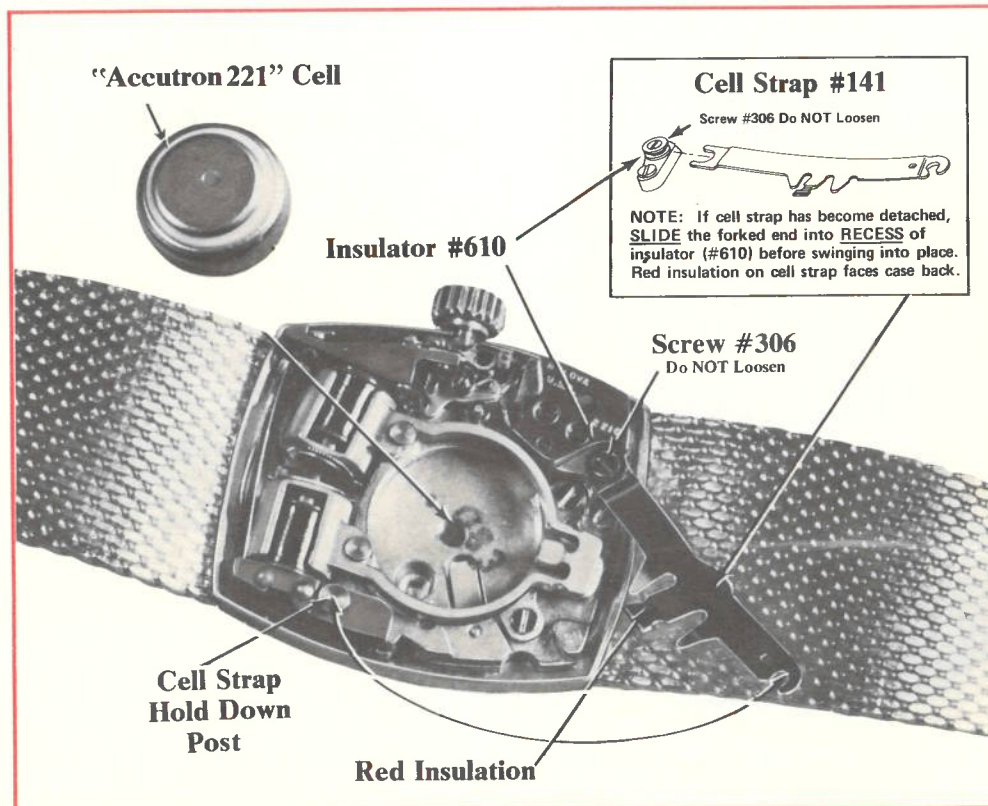

Fig. 7

Regulation

Rate Recorder

The Bulova Vibrograf B200A is the only time testing device recommended by Bulova for testing tuning fork movements including the new model Accutrons by Bulova. It incorporates all the latest technological advances—solid state circuitry, modular construction and a hermetically sealed quartz crystal for utmost accuracy.

Yet, with all its advanced features, the B200A is remarkably easy to use. Just place the timepiece on the holder and the Vibrograf starts printing a clear crisp image. No warm-up time is needed. Take the watch off and the system stops.

FEATURES

- All transistor solid state circuitry. No tubes to burn out. No warm-up time.
- Modular construction. Parts can be popped in and out for fast easy service.
- Permanent pressure sensitive paper. No messy ink ribbons. Rate is graphically recorded in a crisp sharp image.
- Automatic paper feed system. Paper feeds only when timepiece is on the watch holder.
- The Bulova Vibrograf is the only rate recorder we recommend to check tuning fork movements.



Fig. 11

ACCUTRON REGULATORS

The 221 ACCUTRON regulators are calibrated with eight divisions to provide easy reference during regulation. Each division is equal to 2 seconds per day of correction; in other words, rotating one of the regulators a distance equal to one division changes the rate of the ACCUTRON timepiece by 2 seconds per day. The amount that a regulator is rotated can be easily gaged by reference to the dot on the top of each cup. (Fig. 12) **If adjustment is more than two (2) seconds per day, it is good practice to divide the adjustment between the two regulators.**

Since there are 8 divisions on each of the regulators, and since each division is equal to 2 seconds per day, it would be impossible to make a correction of more than 32 seconds per day, even if both regulators were originally set all the way in one direction. If the timing rate is beyond regulation, turn to the diagnostic chart on Pages 14 & 15.

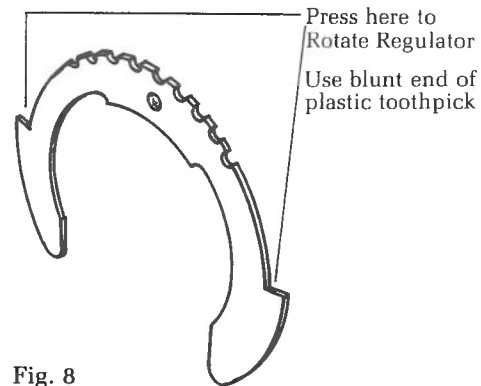

Fig. 8

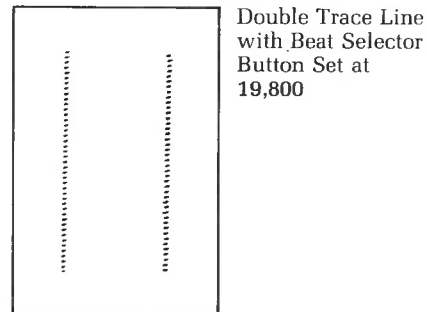

Fig. 10

HOW TO REGULATE

Note: The basic accuracy of the ACCUTRON tuning fork is such that regulation for more than a few seconds per day is not required. Gains or losses of two minutes or more a week usually indicate the need for repair, not regulation.

The Series 221 ACCUTRON, in the **dial-up** position, should be regulated to plus two seconds (+2) per day, when worn on the **outside** of either wrist.

Note: For those people who wear a Series 221 ACCUTRON watch on the **inside** of the wrist, regulation would be **minus** two seconds (-2) per day in the **dial-up** position.

If your customer returns a watch for regulation, indicating that it gains or loses beyond the guaranteed limits of plus or minus one minute per month, proceed as follows:

1. BEFORE OPENING THE CASE, check the rate of the watch with an ACCUTRON Rate Recorder, Vibrograf Model B100A or B200A with beat selector set at 19,800. Compare the results with the customer's report, being certain that there is no discrepancy (gains instead of loses or vice-versa).
2. Open the case, as instructed on Pages 4 & 5.
3. Using a pegwood or plastic stick, rotate one or both of the regulators (Fig. 12) a sufficient number of divisions necessary to make the required correction. Rotating a regulator **away** from the **center** of the movement will cause the ACCUTRON timepiece to run **slower**; rotating a regulator **toward** the **center** of the movement will cause it to run **faster**.

To regulate 2 seconds per day **faster**, move either regulator one division **towards** the center of the movement, as shown.

To regulate 2 seconds per day **slower**, move either regulator one division **away** from the center of the movement, as shown.

Divide the adjustment between the two regulators, whenever possible.

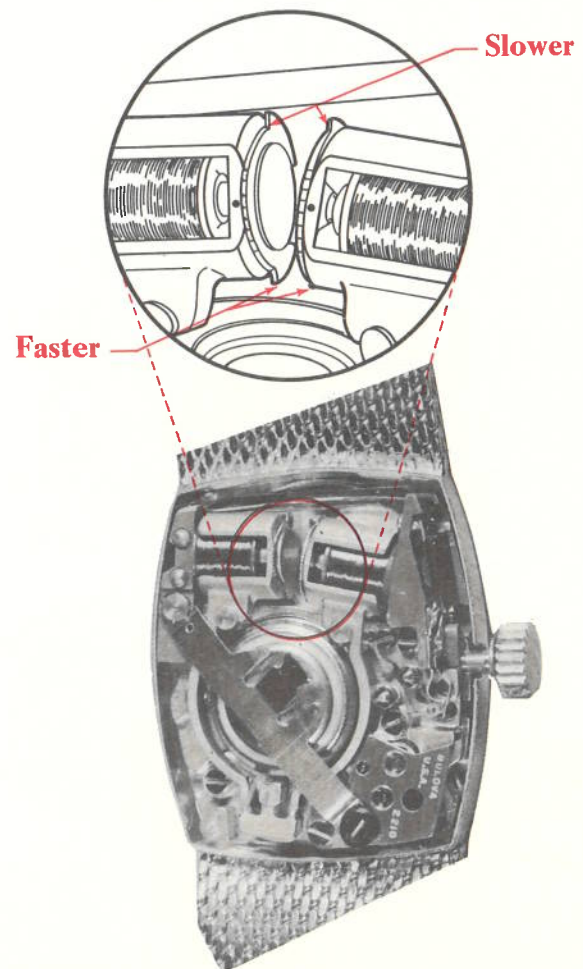

Fig. 12

SECTION II — GENERAL INFORMATION

Special Tools, Equipment and Lubricants

The following tools, equipment and lubricants are required to perform diagnoses and to service the Series 221 ACCUTRON movement:

1. ACCUTRON Test Set (Model 700)
2. Movement holders
3. Locking-ring wrench
4. Collet adjusting tool
5. Post bending tool
6. Index post support strip
7. Index wheel holder
8. Lubricants
9. Microscope
10. Ultrasonic cleaning machine
11. Rate recorder

TEST SET

The Model 700 Test Set, illustrated in Fig. 13, is an essential unit in servicing the 221 ACCUTRON movement. The Test Set is used to perform three very important functions:

1. It provides a high resistance voltmeter to check the ACCUTRON Power Cell. (Conventional low-resistance voltmeters are not suitable for this purpose.)
2. It is designed to check the current in the electronic circuit, to indicate its operating condition. (Conventional high-resistance microammeters are not suitable for this purpose.)
3. It provides an accurate source for the reduced voltages required for the adjustment of all ACCUTRON indexing mechanisms. (Voltage requirements are not the same for all types of ACCUTRON movements.)

Note: The Model 700 Test Set is designed for use with the 214, 218, 221 and 230 ACCUTRON movements.

Note: If you already own an ACCUTRON Test Set #600, you can have it modified to handle the ACCUTRON Series 230 and 221 as well.

Contact: Watchmaster Products
62-10 Woodside Avenue
Woodside, N.Y. 11377

THE TEST SET PROVIDES:

1. A "nest" to hold a Power Cell during testing. The nest is clearly marked for proper insertion of the 214, 218, or the 221 Power Cell.
2. A meter, reading either volts or microamperes, indicating the correct values by a clearly marked dial.
3. A 4-position rotary switch:
Position 1 — "Check Power Cell"
Position 2 — "Off"
Position 3 — "Read Microamperes"
Position 4 — "Low Amplitude" (In this position, the Test Set supplies the appropriate reduced voltage for the important indexing mechanism adjustment.)
4. A 2-wire lead, with a spring clip for attachment to the 214 Accutron movement.
5. A 3-wire lead, with a set of alligator clips and plug for attachment to the 218 movement and movement holder, as well as for the 230 movement and the 221 movement.
6. A black adjustment screw, directly below the center of the movement dial, for "zeroing" the meter needle.

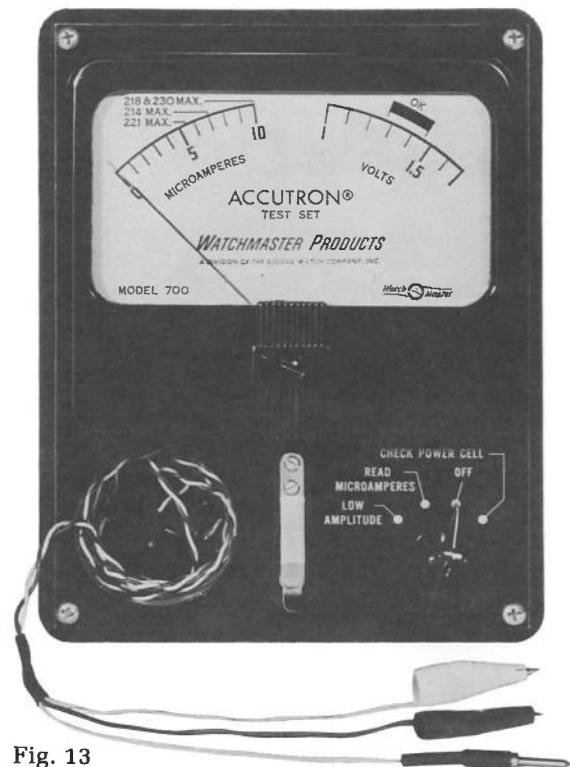

Fig. 13

MOVEMENT HOLDERS

The movement holders (Fig. 14) are specially designed for the 221 ACCUTRON movement and are used to hold the movement whenever it is removed from the case.

LOCKING-RING WRENCH — METAL

A wrench, designed for opening stainless steel cases (Fig. 15)

LOCKING-RING WRENCH — PLASTIC

A wrench, designed for opening gold cases (Fig. 16)

COLLET ADJUSTING TOOL

This tool, illustrated in Fig. 17, is used to adjust the engagement of the index finger and to pre-position the pawl finger. It is inserted in the index finger collet or the pawl finger collet and gently turned to position the index or pawl jewel. **Be careful not to spread the collet opening and cause the collet to become loose when using this tool.**

POST BENDING TOOL — INDEX AND PAWL

This tool, illustrated in Fig. 18, is used to adjust the height of the index and pawl fingers. The tubular portion fits gently over the index or pawl posts in order to raise or lower the height of the jewel on the index wheel, without altering the squareness of the jewel to the index wheel.

INDEX POST SUPPORT STRIP

This support strip, illustrated in Fig. 19, is specifically designed for use in conjunction with the post bending tool. The post of the tuning fork tine must be supported from beneath in order to assure that the tine is not inadvertently overstressed during the adjustment of the post. The support strip must also be used when replacing the index finger.

INDEX WHEEL HOLDER

The index wheel requires special handling care in cleaning to prevent damage to the index teeth. For this purpose, it is necessary to use a suitable tool to support the index wheel pivots when immersing the index wheel in the ultrasonic cleaner. **Never** handle the index wheel by the rim. Grasp the worm gear only. The index wheel holder is shown in Fig. 20).

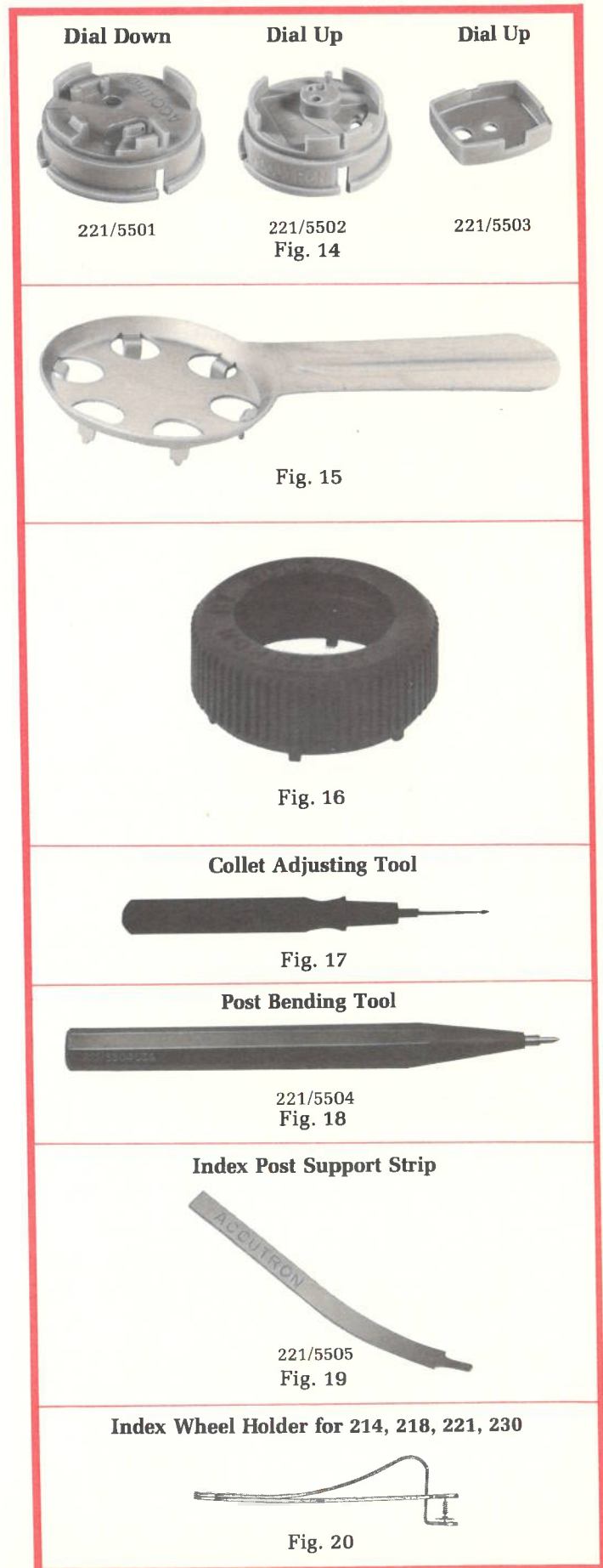

LUBRICANTS

MOEBIUS OL219 — Synta Visco Lube (V) 9020
Used for train wheel jewels

MOEBIUS OL207 — Special Lubricant with Molybdenum Disulfide (M) 8201

Used on fourth wheel assembly, setting mechanism, and dial train.

DOW CORNING COMPOUND #11 (C)
Used for the cannon pinion post.

Lubricants are available at your Authorized BULOVA Material Distributor.

MICROSCOPE

MODEL — 9020 MONOCULAR (Fig. 21)

30 Power Upright Image
All Steel Construction
Baked Enamel Finish

BINOCULAR

- Magnification range: 10x, 15x, 20x, and 30x.
- Two integral lighting systems — one for above the work and one to silhouette from below. They operate simultaneously or individually.
- Separate control for upper lighting field.
- Micrometer focusing control including diopter adjustment (+4 to -4).
- Plenty of room to work while viewing object through lens.
- Bulova precision construction and quality throughout.
- Rack and pinion elevation control has tension adjustment.
- Turret head rotates 360° so you can look through eye piece from any position.

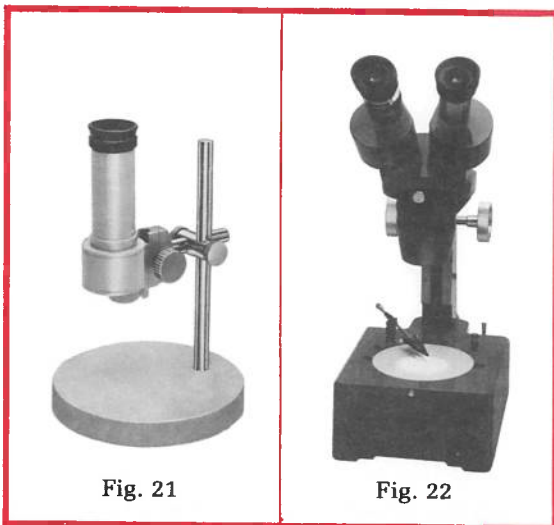

Fig. 21

Fig. 22

Ultrasonic Cleaning Equipment



Fig. 23

MARK II ULTRASONIC WATCH CLEANER

New solid state triac controlled variable speed dryer with automatic temperature control provides optimum cleanability and drying in minimum time.

The Watchmaster Ultrasonic Mark II will deep scrub watch movements sparkling clean without removal of cap jewels, balance, time and dial trains or setting parts. More than a watch cleaner Watchmaster Mark II is actually a whole system. Ultrasonic cleaning, spin-drying, and rinsing all perfectly done by 1 compact unit. Mark II removes deeply encrusted grime away quickly, economically, and dependably with the ease and delicacy expected from a Bulova product.

FEATURES

- Watches can be cleaned without being completely disassembled
- Economical — only 6 oz. of solution per cup
- Stainless steel cups are corrosion free
- Choice of spin-dry speeds from 500 to 1800 RPM
- Choice of drying with or without heat

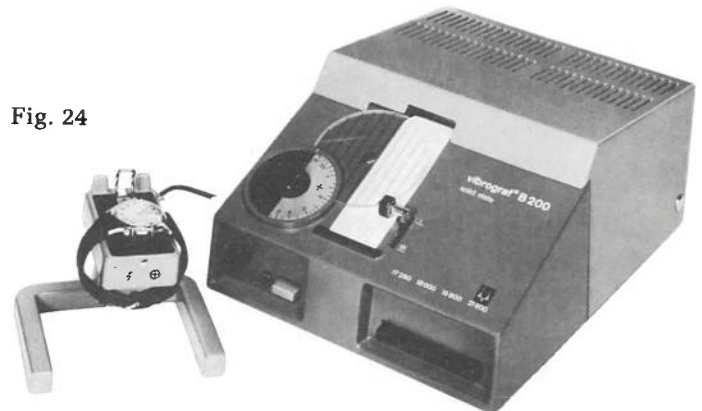

Fig. 24

Note: For further information on the ACCUTRON Test Set, The ACCUTRON Power Cell Tester, ACCUTRON Microscopes, Watchmaster Ultrasonic Cleaner or the ACCUTRON Rate Recorder, write to:

Watchmaster Products, Div. of Bulova Watch Company, Inc.

62-10 Woodside Ave., Woodside, N.Y. 11377

Terminology

AMPLITUDE	Distance the tine of the tuning fork travels.
DEMAGNETIZED TUNING FORK	A tuning fork that has lost part of its magnetism, causing an excessive current reading on the Test Set.
ENGAGEMENT	Amount of tension applied by the index and/or pawl fingers against the index wheel.
EXCESSIVE CURRENT	With Test Set in "read microamperes", any current reading above 7 microamperes.
EXHAUSTED POWER CELL	A Power Cell whose voltage is below 1.25 volts when checked on an ACCUTRON Test Set or an ACCUTRON Power Cell Tester.
FREQUENCY	Rate at which the tuning fork vibrates or number of vibrations per second (Hz.). The frequency of the Series 221 ACCUTRON tuning fork is 440 Hz. (cycles per second).
MECHANICAL BLOCKAGE	When the motion of the tuning fork or train wheels has been mechanically impaired, usually because of foreign matter or a dislodged screw.
METER PEGS	When the needle of the ACCUTRON Test Set jumps to the extreme right hand side of the dial, indicating a very high current draw or short circuit.
MOMENTARY HESITATION	When the index wheel does not run smoothly with the ACCUTRON Test Set in the "low amplitude" setting. Note: There is absolutely no hesitation permitted when the ACCUTRON Test Set is in the "read microamperes" position.
OPEN CIRCUIT	A circuit whose flow of current has been interrupted by a break (meter reads zero).
OVERAMPLITUDE	Index wheel advancing more than one tooth at a time, due to excessive amplitude of the tuning fork.

PHASING

Turning the pawl bridge cam to adjust the pawl jewel's relationship to the index jewel in order to obtain a smooth run of the index wheel. The rotary switch of the Test Set must be in the "low amplitude" position.

PAWL PRE — POSITION

Disengaged position of the pawl jewel prior to phasing.

PRE-TEST or FREE FORK TEST

A check of the tuning fork and coils' operation prior to adjusting and phasing the indexing mechanism. This assures that the electrical portion is operating.

SHOCKED TUNING FORK

A watch which has received a severe external blow with the result that the Tuning Fork is running slow. It may be necessary to change the fork if the slow rate is not within the range of regulation.

SHORT CIRCUIT

An excessive current between two points (meter pegs). A faulty electrical connection. (Not necessarily a shorted coil.)

TINE

One arm of the tuning fork.

Checking Train Freedom

This check is used to determine whether there is any mechanical blockage of the gear train.

The most sensitive and convenient method of checking the train freedom is to pluck, or "twang", the tine of the tuning fork to which the index finger is attached. When this is done, the fork will vibrate for a few seconds and this motion will be transmitted to the train — if it is not blocked.

The motion of the train can easily be seen by watching the index or second wheel at the time that the fork is being plucked. If no motion of the gears is apparent when the fork is plucked, this is evidence of a blocked train. Check the endshake of the train wheels:

Index Wheel — .02 to .04 mm.
2nd, 3rd and 4th Wheel — .02 to .06 mm.

Because of the use of the worm gear arrangement, the train can NOT be rotated by turning the hands or fourth wheel. With the index and pawl fingers disengaged from the index wheel, direct a gentle stream of air from a "blower" on the index wheel. The wheels must turn freely and show no evidence of binding.

Symptom	Possible Cause	Diagnostic Procedure	Corrective Action Required
Gaining or losing excessively (minutes per week)	1. Hands rub or catch slightly	Check crystal clearance. Inspect for adequate clearance between hands and between hands and dial markers or crystal.	Adjust hand clearance.
	2. Poor contact between cell strap and Power Cell.	Inspect Power Cell and cell strap for an adherent deposit of dried electrolyte which may sometimes "push" the cell strap away from the Power Cell.	Clean cell strap and replace Power Cell as described on Pg. 7.
	3. Indexing mechanism out of adjustment	Check adjustment of indexing mechanism (Pg. 21)	Adjust indexing mechanism, if necessary (Pg. 21). Phasing (Pg. 23).
	4. Mechanical interference with free vibrations of fork.	Check movement current (Pg. 18). If current is above seven (7) microamperes, rotate index finger collet to disengage jewel from index wheel. If current remains above seven (7) microamperes, fork may be blocked or partially demagnetized. See "Special Points" Pg. 16, Item 9, and Pg. 20, Fig. 49.	Remove blockage. Readjust indexing mechanism. (Pg. 21). Phasing (Pg. 23).
	5. Train partially blocked	If movement current was above normal in Step 4 (above) but current is below seven (7) microamperes with index mechanism disengaged, train is partially blocked. Check train freedom (Pg. 13).	Remove blockage. Readjust indexing mechanism. (Pg. 21). Phasing (Pg. 23).
	6. Damaged teeth on index wheel	See "Special Points" Page 16, Item 3.	Replace index wheel assembly procedures (Pg. 27) Check adjustment of indexing mechanism (Pgs. 21 & 22).
STOPPED no hum	1. Crown in "setting position"	Check to see if crown is pressed "in".	Press crown "in".
	2. Exhausted Power Cell	Open case, remove Power Cell and check its voltage (Pg. 6) If voltage is low, Power Cell is exhausted.	Replace Power Cell (Pg. 7)
	3. Open drive coil	Check movement current (Pg. 18). If no current, one of the drive coils is "open".	Identify defective coil (Pg. 19) and remove same. The coil assembly can be replaced without disturbing the indexing mechanism or removing the fork or train wheels. (See Pg. 24) Re-phase (Pg. 23).
	4. Mechanical blockage of tuning fork.	If movement current is above seven (7) microamperes Step 3 (above), rotate index finger collet to disengage jewel from index wheel. If current remains above seven (7) microamperes, fork may be blocked.	Remove blockage. Readjust indexing mechanism. (Pg. 21). Phasing (Pg. 23).
	5. Faulty electronic circuit	If movement current is high and tuning fork is not blocked, electronic circuit may be faulty. Replace coil assembly. If still high, check for partially demagnetized fork (Pg. 20, Fig. 49).	Identify defective coil (Pg. 19) and remove same. The coil assembly can be replaced without disturbing the indexing mechanism or removing the fork or train wheels. (Pg. 24) Re-phase (Pg. 23).

Symptom	Possible Cause	Diagnostic Procedure	Corrective Action Required
HANDS STOPPED hums			
	1. Power Cell voltage low	Open case, remove Power Cell and check its voltage. (Pg. 6). If voltage is low, Power Cell is exhausted.	Replace Power Cell (Pg. 7).
	2. Indexing mechanism out of adjustment	Check adjustment of indexing mechanism (Pg. 21)	Adjust indexing mechanism (Pg. 21). Phasing (Pg. 23).
	3. Mechanical interference with free vibrations of fork	Check movement current (Pg. 18). If current is above seven (7) microamperes rotate index finger collet to disengage jewel from index wheel. If current remains above seven (7) microamperes, fork may be partially blocked.	Remove blockage. Readjust indexing mechanism (Pg. 21) Phasing (Pg. 23).
	4. Mechanical blockage of train	If movement current was above normal in Step 3 (above) but current is OK with index mechanism disengaged, train is partially blocked. Check train freedom (Pg. 13).	Remove blockage. Readjust indexing mechanism. (Pg. 21).
	5. Dirt in teeth of index wheel	If above checks prove negative, connect Test Set with switch in "Read Microamperes" position. With crown "in", tap movement holder with finger to increase fork amplitude while observing closely with loupe. If index wheel rotates once, then stops again, there may be dirt in index wheel teeth.	Remove index wheel (Disassembly procedures Pg. 27) Clean wheel and reassemble (Pg. 28) Readjust indexing mechanism. (Pg. 21) Phasing (Pg. 23).
	6. Damaged teeth on index wheel	If test in Step 5 (above) proves positive but is not corrected by cleaning index wheel, index wheel teeth have been damaged. Replace index wheel.	Replace index wheel (Disassembly procedures Pg. 27 and reassembly procedures Pg. 28) Readjust indexing mechanism (Pg. 21) and Phase (Pg. 23).
	7. Hands catch	Inspect for adequate clearance between hands and between hands and dial markers.	Adjust hand clearance
	8. Stoppage in dial train	If hand clearances are satisfactory, remove dial and hands (Pg. 24). Inspect for cause of interference.	Correct blockage
	9. Loose fourth wheel assembly	If index wheel turns, but hands do not move, fourth wheel assembly may have lost its torque.	Replace fourth wheel assembly (Pg. 27).

Special Points For The Accutron Repairman

WHENEVER POSSIBLE, FIND OUT EXACTLY WHAT THE CUSTOMER'S COMPLAINT IS BEFORE YOU ATTEMPT CORRECTION.

REMEMBER: To save time, therefore money, tests should be performed **prior** to disassembly. Determine the problem and where it is. This will allow for disassembly only as necessary, and possibly not for complete disassembly.

The ACCUTRON movement, being completely different from conventional watch movements, requires different techniques in its repair. Otherwise, it may be damaged by improper procedures on the part of the repairman.

- 1. Removing and Replacing Hands:** The Series 221 ACCUTRON is designed with a floating cannon pinion. The hands need not be removed from the dial prior to removing the dial from the movement. By aligning the hands to "12 o'clock" when assembling the movement, the dialing operation should present no difficulties. A special dial washer has been designed for this Series. Never attempt to change its contour or use any substitute. This dial washer must contain **no** burrs or sharp bends in order to operate as required.
- 2. Removing and Replacing Stem:** As with conventional watches, the stem should preferably be pulled "out" (setting position) before loosening the setting lever screw to remove the stem. The setting lever screw head is located in circular cut-out of the pawl bridge below the switch springs. Care should be exercised when loosening this screw. The use of a proper fitting screwdriver of correct size is essential in order not to dislodge or shift the pawl bridge, nor distort the springs of the disconnect switch.
- 3. Index Wheel:** The teeth on the index wheel will not wear away in normal use, nor can they be damaged as a result of any accident when the movement is enclosed in the case. The index wheel, however, can be damaged by improper handling on the part of the repairman. If it is suspected that the teeth on the index wheel have been damaged, the only solution is to replace it. Always handle the index wheel by its worm gear, **never** by the wheel.
- 4. Lubrication:** Do **NOT** oil the teeth of the index wheel nor the index and pawl finger jewels. The pivot jewels should be oiled only one third ($\frac{1}{3}$) of the diameter of the cap jewel. Recommended lubricants are (V) = **Moebius OL219** (Synta Visco Lube 9020) for the train jewels and (M) = **Moebius OL207** (Special Lubricant with Molybdenum Disulphide 8201) for the setting mechanism, fourth wheel assembly, and the dial train. (C) = **Dow Corning Compound # 11** is required for the cannon pinion post.
- 5. Electrical Contact:** Make a habit of cleaning the underside of the cell strap, which can be done efficiently with an eraser, and wiping any white adherent material. Such material may sometimes act as an insulating layer between the strap and the Cell and thereby break the electrical contact. In such instances, removing the residue, particularly on the underside of the cell strap, will prevent a latent problem that may cause the watch to be returned to you after servicing. Should the cell strap be corroded or discolored where it contacts the Power Cell, replace the cell strap. The plating of the cell strap must remain intact to assure the proper electrical contact. **NEVER REMOVE ANY OF THE INSULATION FROM THE CELL STRAP.** This insulation is a special compound specifically designed for this movement. If the insulation has chipped away or is cracked, replace the cell strap.
- 6. Circuit:** The use of electrical test equipment or procedures, other than those recommended, should be avoided. In particular, circuit elements may be damaged by the use of a multimeter and/or ohmmeter for testing the circuit. The Bulova ACCUTRON Test Set is the only meter recommended to use when servicing any ACCUTRON movement.
- 7. Removing or Replacing The Coil Assemblies:** Coil assemblies can be removed and replaced without disassembling either train or fork or disturbing the indexing mechanism. (See Page 24)
- 8. Magnetism:** Never demagnetize an ACCUTRON movement or intentionally expose the tuning fork to strong magnetic fields.
- 9. Magnets Partially Demagnetized:** Experience has shown that demagnetized tuning fork magnets are **very** rare. If the movement current is below seven (7) microamperes with index and pawl fingers engaged, the magnets are satisfactorily magnetized. A reading above seven (7) microamperes does not **automatically** indicate a demagnetized magnet (See Page 20).
- 10. Temperature Effect on Movement:** The heat of a bench lamp will not affect the current readings of a Series 221 ACCUTRON movement. Unlike other type ACCUTRON movements, the Series 221 ACCUTRON movement shows no appreciable increase in current consumption when warm.
- 11. Adjustment of Indexing Mechanism:** It is always good practice to check the adjustment of the indexing mechanism **AFTER** replacing the dial and hands. This is part of the final check-out prior to regulation and casing. In this way, you are assured that the movement is at peak performance.
- 12. Electrical Disconnect System:** This system allows for storage of the movement with the Power Cell installed. When the stem is pulled to the "setting" position, the movement consumes only one-third ($\frac{1}{3}$) microampere of current. With a **fresh** Power Cell installed, the watch may be stored for a year and still operate a full year when the stem is pushed "in" to the run position.

13. **Worm Gear Arrangement:** The unique design of this electronic watch employs a worm gear on both the index and second wheel of the train gear. The use of worm gear arrangement allows for a substantial gear ratio reduction without taking up the necessary space of conventional wheels and pinions. Additionally, the worm gear arrangement protects the index wheel by making it impossible for the index wheel to be rotated in either direction during the setting of the hands.
14. **Tightness of Screws:** You will find that the screws employed in the Series 221 ACCUTRON are firmly screwed in place. The use of proper fitting screwdriver blades are essential in order to avoid breaking the blades or marring the heads of the screws. It is essential that ALL SCREWS BE FIRMLY SEATED. The tightness of the tuning fork, train bridge and coil form screws is extremely important in order to assure a well running movement.
15. **Second Wheel Retainer Clip:** The second wheel and worm gear assembly are horizontal in respect to the other wheels of the train. They are held in place by a permanently staked jewel on one side and a removable jewel bushing on the other. This jewel bushing is held in place by a retainer clip. During repair, this clip must be removed. When replaced, it is important that the spring tension of this clip be exactly as designed and that the jewel bushing be held in place by BOTH arms of the retainer clip. If this clip should become distorted, replacement — rather than adjustment — is highly recommended.

Electrical Disconnect System — Inspection and Adjustment

1. When the stem is pulled “out” (setting position), the contact closes, causing the tuning fork to stop vibrating and the current will be reduced to one-third ($\frac{1}{3}$) microampere. This drain is negligible and allows for storage of the movement with the Power Cell installed, without causing harm to the movement. When the stem is pushed “in” (running position), the movement runs. The following operational checks are recommended:
 - A) On incoming servicing
 - B) During “Pre-test”
 - C) During final casing after servicing movement

Note: Should the switch malfunction or fail to operate, the watch will continue to run whether the crown is in the “in” (run position) or “out” (setting position).

Mechanical check

1. **Stem Out (Setting Position):** Switch spring must be in contact with switch strap and there must be clearance between switch spring and setting lever post. (Fig. 27).

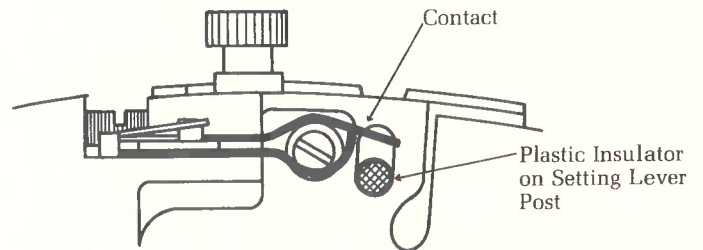

Fig. 27

2. **Stem In (Running Position):** There must be clearance between switch spring and switch strap. This clearance should be at least the thickness of the switch strap. (Fig. 28).

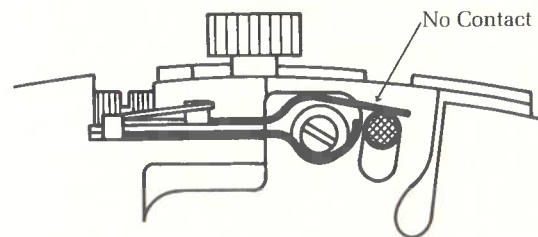

Fig. 28

Electrical check

1. **Stem Out (Setting Position):** Maximum current reading of one-third ($\frac{1}{3}$) microampere at “read microamperes”.
2. **Stem In (Running Position):** Current readings from 2 microamperes to 7 microamperes at “read microamperes” — depending on when the check is made: with index jewel engaged or disengaged with the index wheel.

Note: If the contact is mechanically and visually correct, but the movement continues to run with the crown in the “out” (setting position):

- A. Remove any foreign matter preventing good electrical efficiency, or
- B. The switch circuit is defective, necessitating replacement of the Component Coil Assembly.

Testing The Electronic Circuit

The meter is the single most important diagnostic tool available to today's watchmaker. It adds the ability to "see" and test the performance of the electronic elements. Without the special Bulova meter, proper servicing of an ACCUTRON is impossible.

Zero the Test Set

In order to obtain the maximum accuracy from your Test Set, you must check to see that the meter is zeroed correctly.

Place the test meter in the position most frequently used by you, either in the horizontal position (with the case flat) or in the vertical position (with the case on end) and turn the switch to the **Power Cell Check** position. Do **not** attempt to zero the meter with the switch in the "off" position because the meter movement is dampened to protect it from damage in that position. **Without** a Power Cell in the nest, the meter movement pointer should read exactly on "0", as shown in the diagram below.

If the pointer is **off** zero, leave the meter in the position you use it and take a small screwdriver and turn the **black screw at the center bottom** of the meter movement slightly in either direction, until the pointer rests exactly on zero. Only a slight adjustment should be necessary. It is suggested you rock the test meter back and forth a few times to make sure the needle resets to "0" each time.

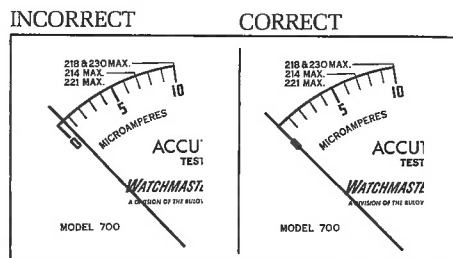

Fig. 29

Zero The Test Set

Note: We recommend that you turn the meter **OFF** to protect the delicate meter movement when the Test Set is **not in use** and particularly when it is being transported. When not using meter, remove power cell.

Check Power Cell

1. Insert a Power Cell into the nest of the Test Set and check that the voltage is within the "O.K." area.
2. Turn the rotary switch to "read microamperes". **Remember:** current readings are taken in "read microamperes"; the "low amplitude" setting is used for phasing **only**.

Check Test Set

3. Touch the two alligator clips together momentarily. The needle of the meter will snap quickly to the right hand side of the scale (Fig. 32). This test indicates that the Test Set is operating properly.

Attach meter to movement

4. Carefully connect the two alligator clips to the movement. Make sure the crown is in the "in" position.
5. With the rotary switch in the "read microamperes" position, the needle will advance to the right hand side of scale.

Note: It may be necessary to tap the movement or "twang" the tuning fork to start it vibrating. Once the tuning fork is vibrating, the needle will move left and should be in, or near, the prescribed area.

Observe the current reading:

6. Shown below are the possible readings and what they indicate. An explanation is given for each, and a course of action is outlined when corrective action is required. **FIRST**, determine which reading applies to your watch, **THEN**, read the explanation and proceed as outlined. (Turn to page indicated under the type of reading that applies.)

UP TO 7 MICROAMPERES

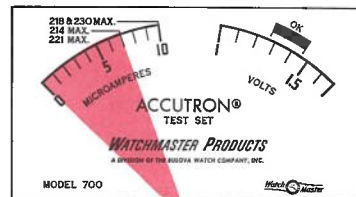

Page 19
Left Column

Fig. 30

Open Circuit

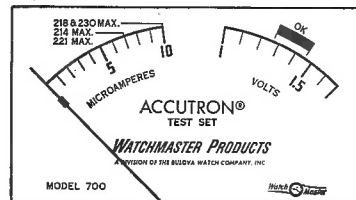

Page 19
Right Column

Fig. 31

Short Circuit

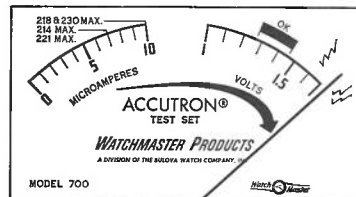

Page 20
Left Column

Fig. 32

Mid Scale



Page 20
Both Columns

Fig. 33

High Reading

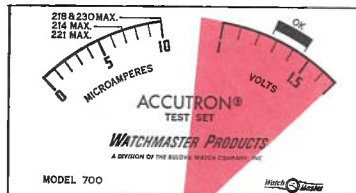

Page 20
Both Columns

Fig. 34

With the index finger engaged with the index wheel

FROM 4 to 7 MICROAMPERES



Fig. 35

A reading of 4 to 7 microamperes is an indication that the **movement is running properly**, provided that:

- The rotary switch is in "read microamperes"
- The index wheel is turning **without hesitation**
- The index mechanism is in "second phase" (See Pg. 23)
- The index and pawl fingers have been **properly adjusted** (See Pg. 21)

With the index finger disengaged from the index wheel

2 to 4 MICROAMPERES

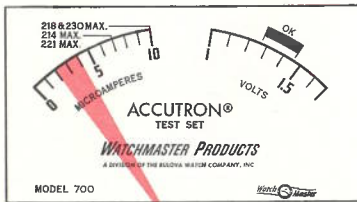

Fig. 36

A reading of 2 to 4 microamperes indicates that the tuning fork and coil assemblies are **functioning properly**, provided that:

- The rotary switch is in "read microamperes"
- The index finger has been **rotated away** from the index wheel

A reading of more than 4 microamperes **with the index finger disengaged** indicates.

- The index finger is **not** perfectly free. It may be hitting the pawl finger or index wheel. Confirm that the index finger is free:
- or**
- There is a small amount of metal slivers on the tuning fork magnets, or a piece of lint is interfering. Remove both of the coils, clean the tuning fork and reassemble. Also check for proper clearance between the tuning fork and both coils. (Pg. 30)

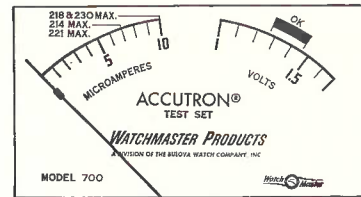

OPEN CIRCUIT

Fig. 38

This reading indicates an **open circuit** provided that:

- The meter is functioning properly.
- The lead strap screw has been checked and is tight
- The stem is in the "in" position

To determine **WHICH** coil assembly is open, proceed as follows:

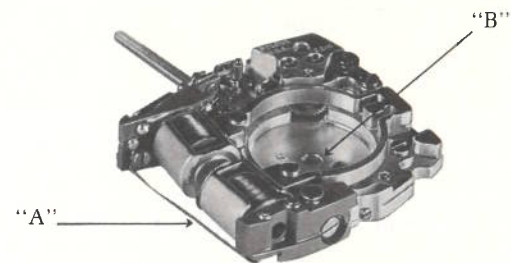
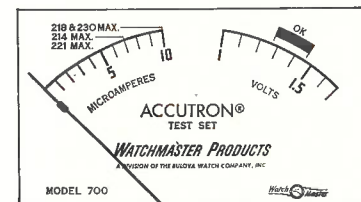

Fig. 39

With movement still connected to meter, touch one tweezer blade to the lead strap "A" and the other tweezer blade to the pillar plate in the area "B" of the cell well.



OPEN CIRCUIT

Fig. 40

If Needle Remains at "0"
Replace **Cell Coil Assembly**

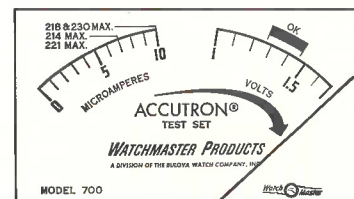

METER PEGS SLOWLY

Fig. 41

If Needle Pegs
Replace **Component Coil Assembly**

SHORT CIRCUIT



Fig. 42

This indicates a **short circuit** usually caused by two meter leads touching. In rare cases, it is an indication that a metal sliver is touching the lead strap or some other electrical connection.

Note: Do not confuse this with a high current reading. When a short circuit is present, the meter needle will jump quickly to the right hand side of the scale causing a “tick” sound. The needle will not bounce away, but will remain jammed against the right hand side.

1. Check the lead wires.
2. Inspect for metal slivers.
3. Check if lead strap connecting coils is touching the dial. Bend sufficiently away from dial to avoid case pressure pushing the dial toward lead strap and causing a short circuit when case is closed.

MID SCALE

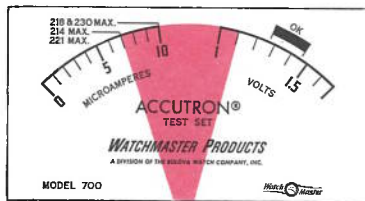

Fig. 43

HIGH READING

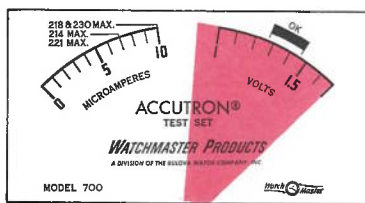

Fig. 44

This indicates **one** of three possibilities:

1. The train gear is mechanically blocked
2. There is a high reading component coil assembly
3. The tuning fork is mechanically blocked or it is partially demagnetized

To determine **which**, proceed as follows:

DISENGAGE THE INDEX FINGER FROM THE INDEX WHEEL AND OBSERVE THE METER READING

2 to 4 MICROAMPERES

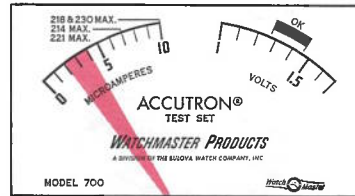

Fig. 45

The **needle returns** to below 4 microamperes. The train is blocked. Find the interference and remove it. The coils and tuning fork are operating correctly and are not at fault.

MID SCALE OR HIGH READING

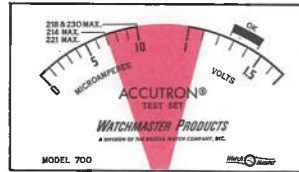

Fig. 46

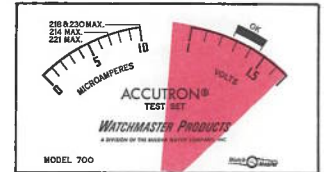
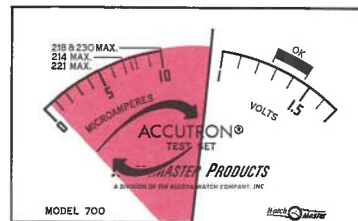

Fig. 47

If the reading still **remains high**, proceed as follows: “Twang” the tuning fork and **observe the needle** of the meter.



DEFLECTS TO OR NEAR ZERO AND RETURNS TO HIGH READING

Fig. 48

The needle deflects **to, or near, “O”**, on the left of the scale and then returns to the high reading:

The magnets of the tuning fork are properly magnetized and the fault lies with the component coil assembly, **providing** the fork is not blocked by metal slivers.

Before replacing it, remove **both** coil assemblies and inspect for metal slivers on the magnets. If any are found, clean the magnets with “One Touch” or similar substance or masking tape and reassemble the same coils. If the high reading still occurs with the needle acting the same way, replace the Component Coil Assembly. Obviously, if there were no metal slivers found when the coils were removed, then replace the Component Coil Assembly right away.

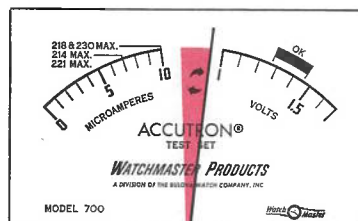

NEEDLE MOVES ONLY A LITTLE

Fig. 49

The needle moves **only a little** to the left when the fork is “twanged”:

The tuning fork is partially demagnetized. Remove both coil assemblies. Should metal slivers be present on the magnets of the tuning fork, it is good practice to remove them with “One Touch” or similar substance or masking tape and reassemble the coils. If the high reading still occurs, with the needle acting the same way, then replace the tuning fork.

Indexing Mechanism — Inspection and Adjustment

The checking and adjustment of the ACCUTRON indexing mechanism is extremely important to its operation. This is accomplished by closely controlling the alignment and the depth of engagement of the index and pawl jewels and their interrelation. Details of the step-by-step procedure necessary to properly accomplish these adjustments are to be performed in sequence as follows:

Note: Perform inspection and adjustment of the electrical disconnect mechanism (Pg. 17) before the following steps:

1. Place movement in movement holder.
2. **Alignment of fingers and jewels** — the lower surfaces of the index and pawl jewels must be parallel to their respective fingers, as shown in Fig. 50. “Toe-in” and “Toe-out” correction can be accomplished, if necessary, without breaking the epoxy attaching the jewel to the finger, by exercising normal watchmaking care:
 - a) Rotate the jewel finger away from the index wheel.
 - b) Grasp the finger with tweezers close to the jewel.
 - c) Press lightly on the end of the jewel or finger in the proper direction with a pointed tool, such as a needle.

For proper operation, the two fingers are straight when they have correct tension (Fig. 51). Obviously, when the fingers are not under tension (disengaged from wheel), there must be a slight curve.

Both of the jewels must be perpendicular or “square” to the wheel (Fig. 52). Either jewel can be made square (perpendicular) to the plane of the index wheel by grasping both the finger and the stress limiter close to their pinning point and twisting slightly (Fig. 53).

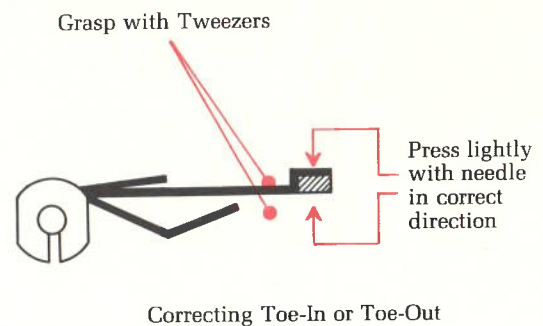
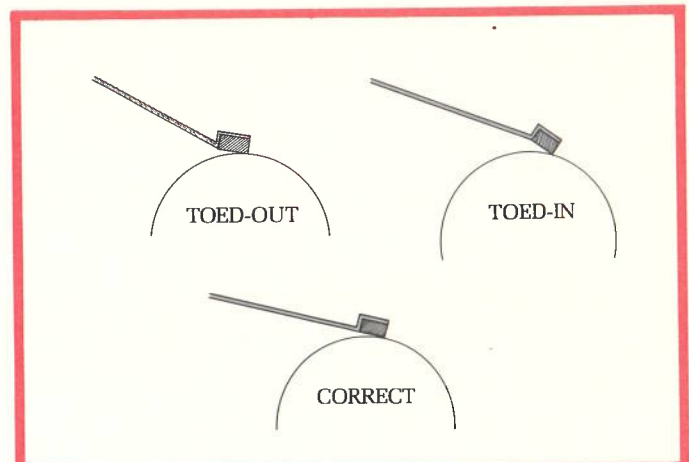

Fig. 50

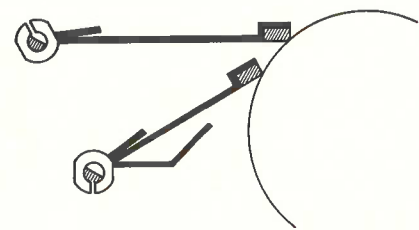

Fig. 51

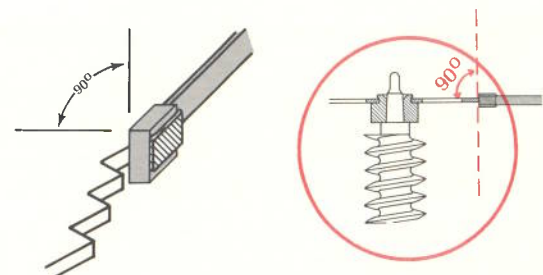

Fig. 52

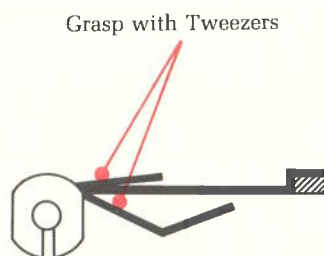
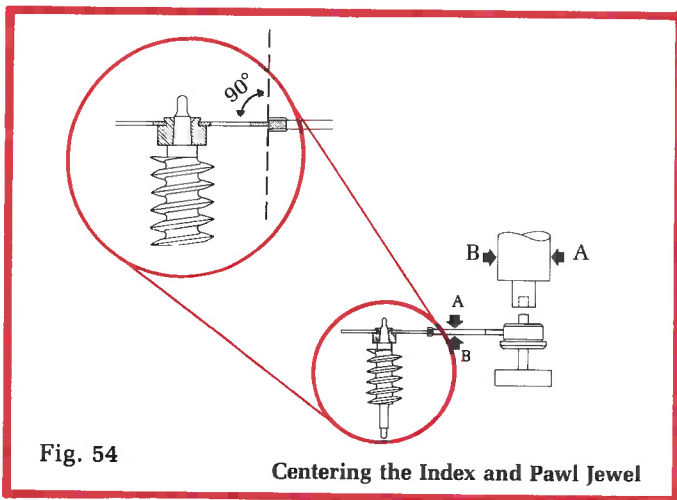
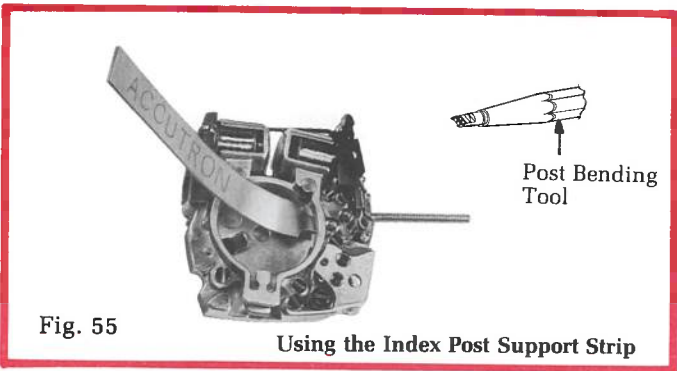

Fig. 53



Centering the index and/or pawl jewel is accomplished by adjustment of the respective post. Gently stress the index or pawl post by pushing the end of the post with the post bending tool (Fig. 54). This very slight bending of the post will raise or lower the index or pawl jewel in relation to the index wheel. When adjusting the index post, the **index post support strip MUST** also be used (Fig. 55).



3. **The Index Finger** — Rotate the index finger collet until index jewel completely disengages from index wheel. Observe gap between index gage and index finger (Fig. 56). The gage must not touch the finger, but preferably should be very close, **not more than one index finger thickness**. This, as you will see, will make it easier to perform Step 4. If gap does not meet requirements, bend index gage at its attached end until the proper gap is obtained. The gage should have an elbow appearance, similar to the one shown. The angle of the elbow bend should **not** be altered.

4. Use the collet adjusting tool to rotate index collet; bring the index jewel into the wheel until the gage gap is larger than it was in Step 3 by 1 to 1½ index jewel thicknesses (Fig. 57). The amount of tension provided by rotating the collet is critical. Do **NOT** proceed until the gage of the index finger is set to within tolerance: **one to one and a half index jewel thicknesses plus original gap**.

Note: Be careful not to spread the collet opening when rotating, to avoid making the collet loose.

5. **Stress Limiter** — observe the stress limiters on index and pawl fingers (Fig. 58). Check that no more than one-third (1/3) of the length of the stress limiter is in contact with the index or pawl finger. Also, check that end of stress limiter is no more than three thicknesses of the stress limiter away from index or pawl finger. If adjustment is necessary, use tweezers to bend stress limiter; then repeat Steps 3 and 4.

6. **Pre-Positioning pawl jewel** — loosen pawl bridge lock screw **slightly** — about one-quarter (1/4) turn. Check that the pawl bridge pivot screw is tight. (Fig. 59).

7. Rotate pawl bridge cam until pawl jewel is in its maximum "out" position (maximum direction to disengage pawl jewel from index wheel). The pawl jewel must not be touching the index wheel and must be less than **ONE-HALF (1/2) ITS THICKNESS AWAY FROM THE WHEEL**. The pawl pre-positioning is adjusted using the collet adjusting tool (Fig. 59).

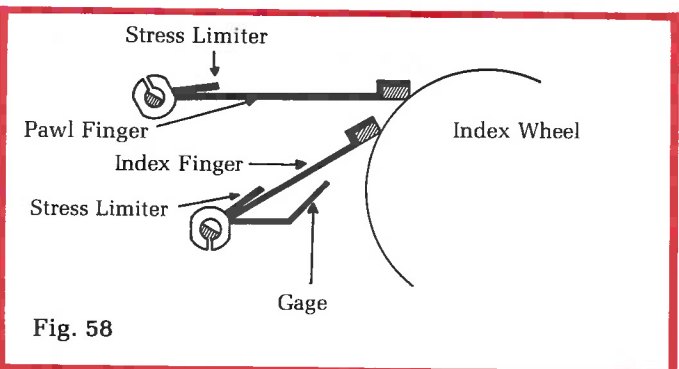
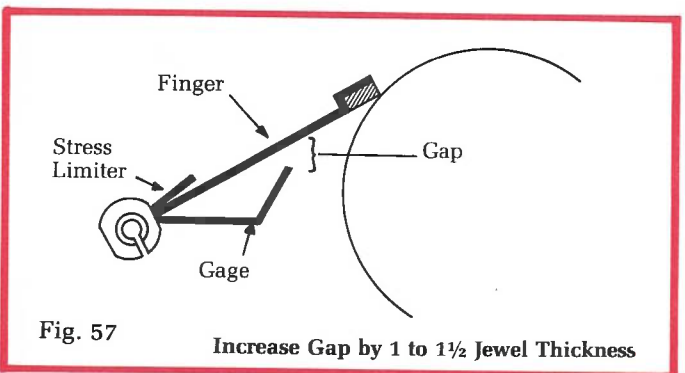
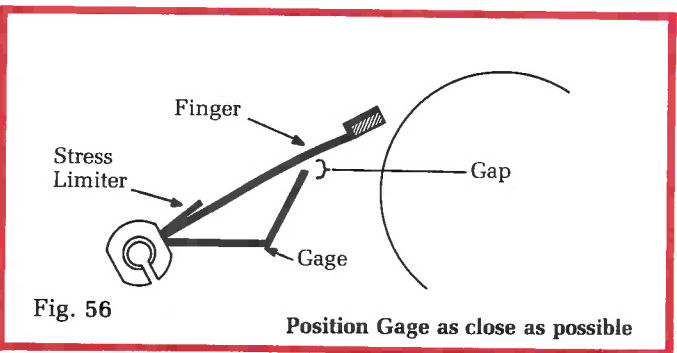

8. **Connecting Test Set** — Connect the meter to the movement using the alligator clips. With Power Cell in the nest of the Test Set, turn rotary switch to “Low Amplitude” position. **With the crown “in”**, if tuning fork does not begin to vibrate, an excess current reading will be indicated on meter of Test Set. Should this occur, tap movement holder lightly and fork will start. With the movement operating correctly the current reading will then drop to about four (4) microamperes.

9. **Phasing** — While viewing the index wheel, rotate the pawl bridge cam **very slowly** in either direction, (since it was at its maximum distance away, rotating either clockwise or counterclockwise will move the pawl jewel toward the wheel) until movement **STARTS**. This can be seen by watching the index wheel. Turn the cam slightly farther until the movement **STOPS**. Continue to turn until it **STARTS AGAIN and continues to run**. (**Momentary Hesitation Permitted**)

Note: Since the pawl bridge lock screw is **snug** (Step 6) — the pawl bridge cam will turn with some resistance.

10. Tighten the pawl bridge lock screw and recheck the tightness of the pivot screw, to assure that the bridge is rigidly clamped in position. The train should continue to run (Test Set switch at “Low Amplitude” position). If it does not, the adjustment must be made again (Steps 7 through 10).

11. Turn rotary switch to “**Read Microamperes**”. With the dial and hands on, the maximum current drain permissible is seven (7) microamperes.

Note: Should the index wheel rotate at “Low Amplitude” but fail to turn at “Read Microamperes”, then the index wheel contains damaged teeth and must be replaced.

ALWAYS USE A 20 or 30 POWER MICROSCOPE WHEN INSPECTING THE INDEXING MECHANISM.

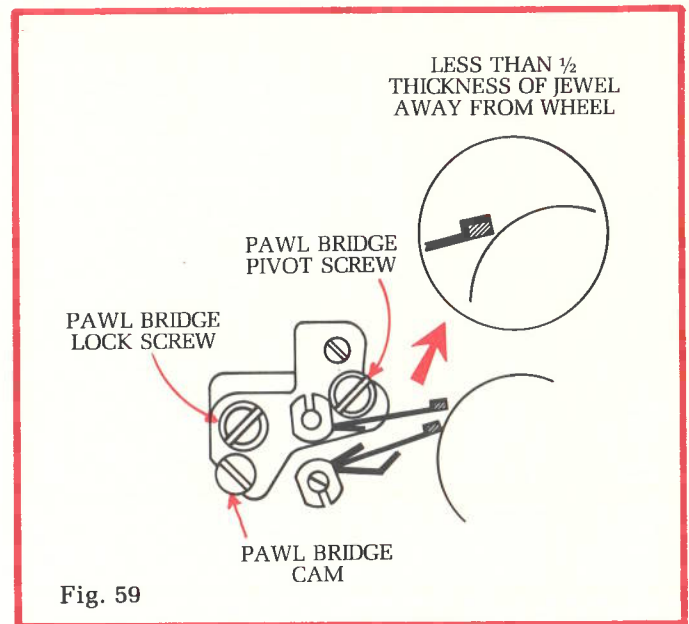

Fig. 59

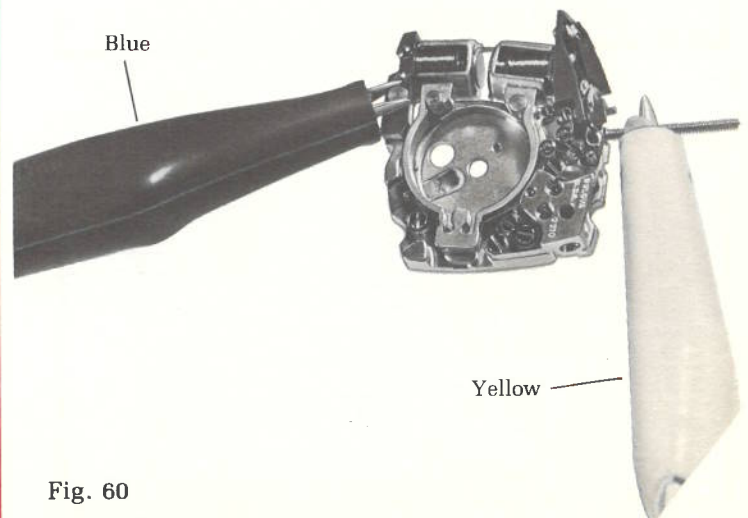

Fig. 60

SECTION III — DISASSEMBLY

Remove dial assembly

1. Loosen the two dial screws (#148) two (2) full turns
2. Remove dial with hands intact.
3. Tighten the two dial screws.

Note: The Series 221 is manufactured with a dial washer of special design. If replacement is necessary, use only Genuine Material.

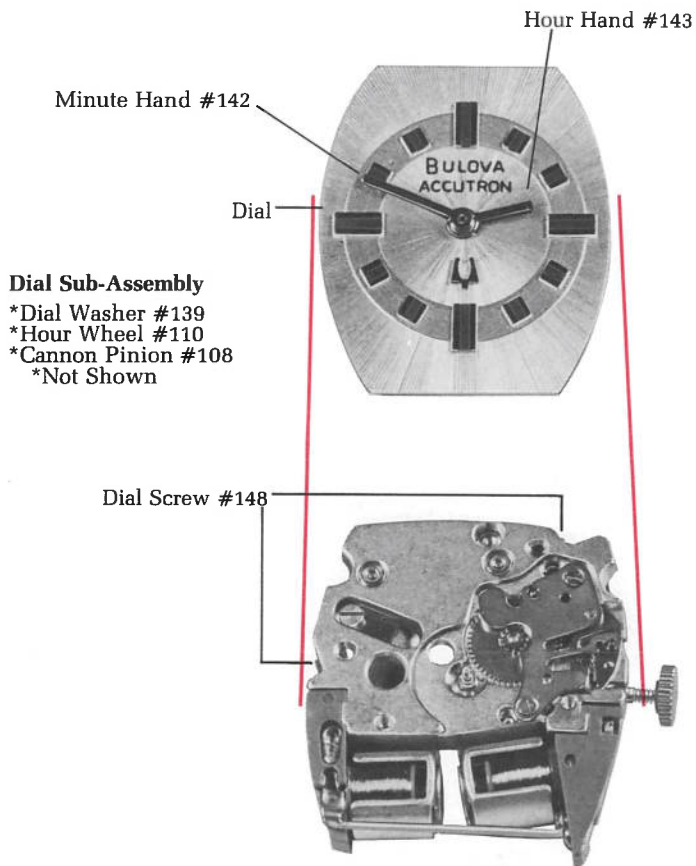

Fig. 61

Remove coil assemblies

1. Loosen, but do not remove, Coil Lead Strap Screw (#304A). Be careful not to slip and cut any of the fine wires of the coil.
2. Unhook lead strap.
3. Remove Cell Coil Assembly Screw (#151).
4. Remove Cell Coil Assembly (#715).
5. Remove Component Coil Assembly Screw (#151).
6. Remove Component Coil Assembly (#712).

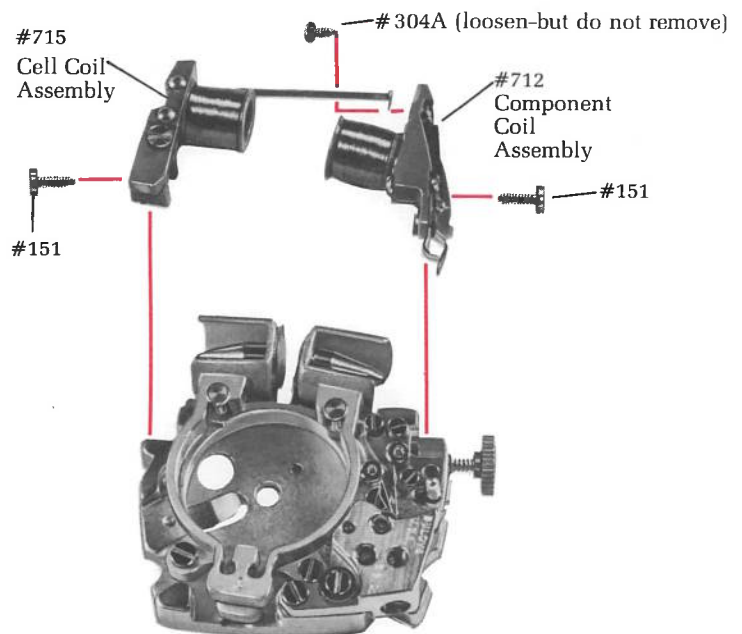

Fig. 62

Disengage index and pawl fingers

1. Push crown to "in" position.

Caution: Be careful not to spread collet opening when rotating, to avoid making collet loose.

2. With use of collet adjusting tool, rotate **pawl** finger away from index wheel until it **almost** touches on the clear insulator near electrical disconnect system.
3. Rotate **index** finger away from index wheel until it clears the edge of the Train Bridge.

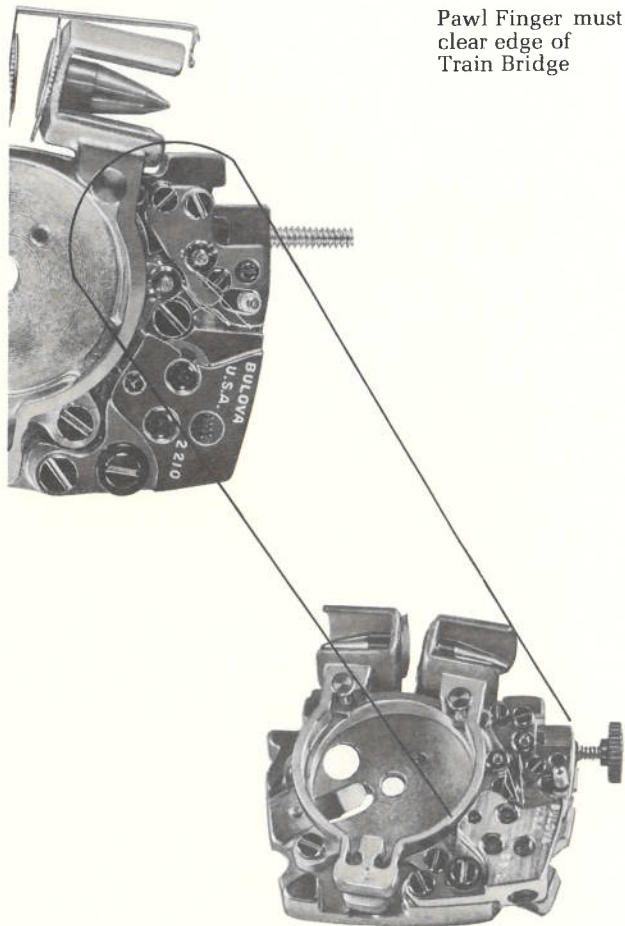

Fig. 63

Remove tuning fork

1. Remove the two Tuning Fork Screws (#183).

Notes:

- a) If tuning fork does not lift off easily, loosen by gently prying in cut-out area provided with a screwdriver blade.
 - b) Using tweezers, grasp tuning fork by the base. **Never** grasp the fork by the tines.
 - c) Be sure to clear shock pins. Do not distort tines of fork.
 - d) Care should be taken not to distort index finger.
2. Remove Tuning Fork (#716) by carefully sliding fork forward and tilting upward until it clears shock pins.
 3. At this point, the movement can be ultrasonically cleaned.

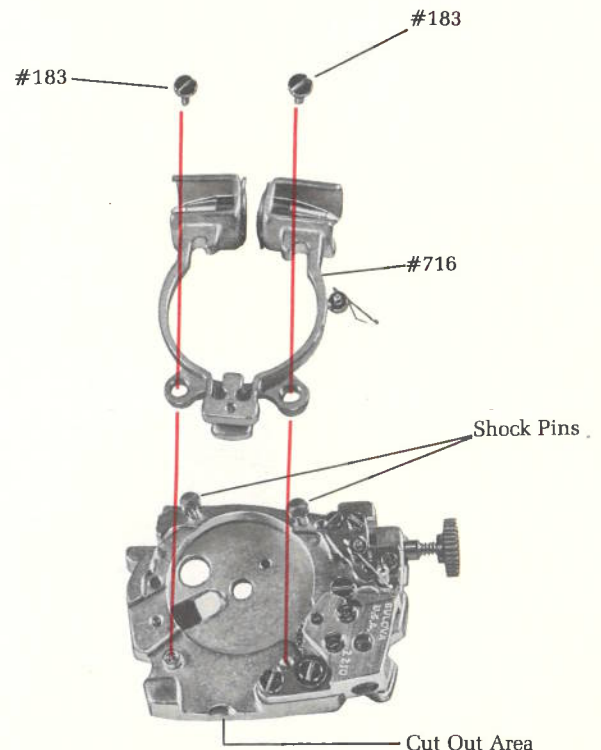

Fig. 64

SECTION IV — SERVICING

MARK II ULTRASONIC WATCH CLEANER

New solid state triac controlled variable speed dryer with automatic temperature control provides optimum cleanability and drying in minimum time.

The Watchmaster Ultrasonic Mark II will deep scrub watch movements sparkling clean without removal of cap jewels, balance, time and dial trains or setting parts. More than a watch cleaner Watchmaster Mark II is actually a whole system. Ultrasonic cleaning, spin-drying, and rinsing all perfectly done by 1 compact unit. Mark II removes deeply encrusted grime away quickly, economically, and dependably with the ease and delicacy expected from a Bulova product.

FEATURES

- Watches can be cleaned without being completely disassembled
- Economical — only 6 oz. of solution per cup
- Stainless steel cups are corrosion free
- Choice of spin-dry speeds from 500 to 1800 RPM
- Choice of drying with or without heat



Fig. 65

Note: The train wheels and bridge need not be removed for ultrasonic cleaning.

Ultrasonic equipment is necessary for cleaning the ACCUTRON movement. The movement should be treated exactly as any fine watch movement, with one exception. The electronic circuit and the tuning fork should **not** be cleaned in ultrasonic equipment because of the possibility of damage to delicate parts.

The tuning fork and coils can be cleaned satisfactorily by dipping into a "Final Rinse Solution" and then placing on a tissue to dry.

Care should be taken to prevent metal chips, which may be present in the cleaning cup or on the bench, from being attracted to the permanent magnets. Inspect the fork carefully after cleaning, and if this has occurred, any particles that are clinging to the magnets can be removed with masking tape or "One Touch". No particles should be left clinging to the fork magnets.

The fourth wheel assembly should **not** be taken apart, but cleaned as a unit. After cleaning, the wheel should not be rotated until properly lubricated. (See Reassembly Instructions, Pg. 28)

When cleaning the index wheel separately the wheel requires special handling care to prevent damage to the index teeth. For this purpose, it is necessary to use a suitable tool to grasp the index wheel pivots when immersing the index wheel in the ultrasonic cleaner. **Never** handle the index wheel by the rim. Grasp the worm gear only. A special index wheel holder, illustrated below is available from your Local Authorized BULOVA Material Distributor.

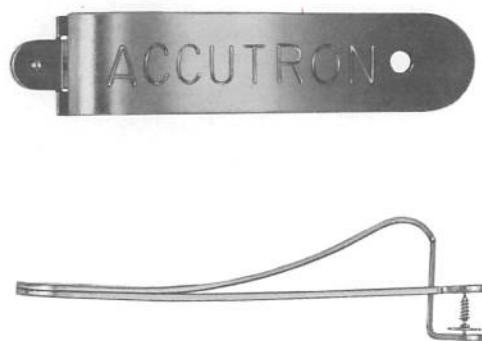

SECTION V — LUBRICATION AND REASSEMBLY

Remove second wheel

IMPORTANT

The second wheel must be removed BEFORE removing the train bridge, NEVER after.

1. Using hairspring tweezers, carefully remove Second Wheel Retainer Clip (#326).

Note: Care should be taken not to cause distortion. Replace if distorted.

2. Remove Second Wheel Jewel Assembly (#325). Assembly will usually fall out if movement is tilted.
3. Remove Second Wheel (#103).

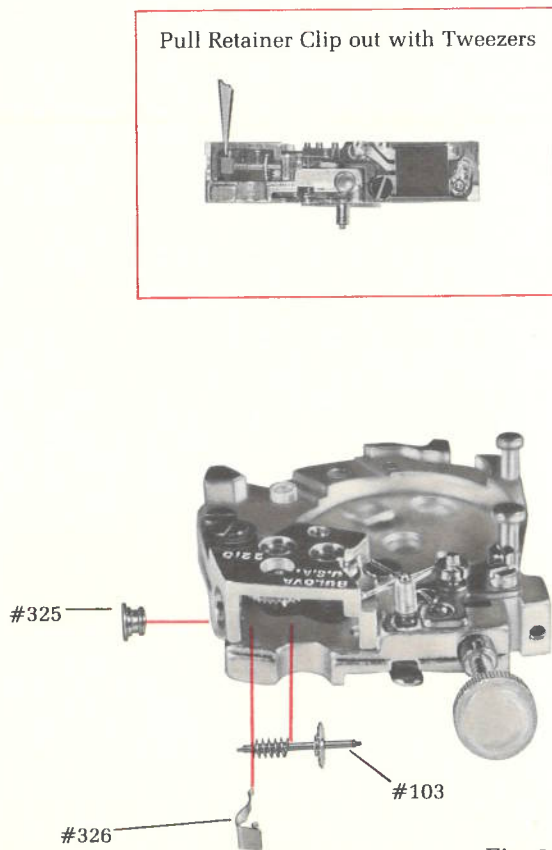

Fig. 66

Remove train bridge and train wheels

1. Remove the two Train Bridge Screws (#125).

Caution: Be careful not to damage index wheel when removing screws.

2. Remove Train Bridge (#404).

Caution: Be careful not to damage Pawl Finger.

3. Remove Index Wheel (#112).

Note: Grasp the index wheel by its worm gear, **never** by its wheel. Place in pithwood to protect the index wheel from possible damage.

4. Remove Third Wheel (#105).
5. Remove Fourth Wheel (#107).

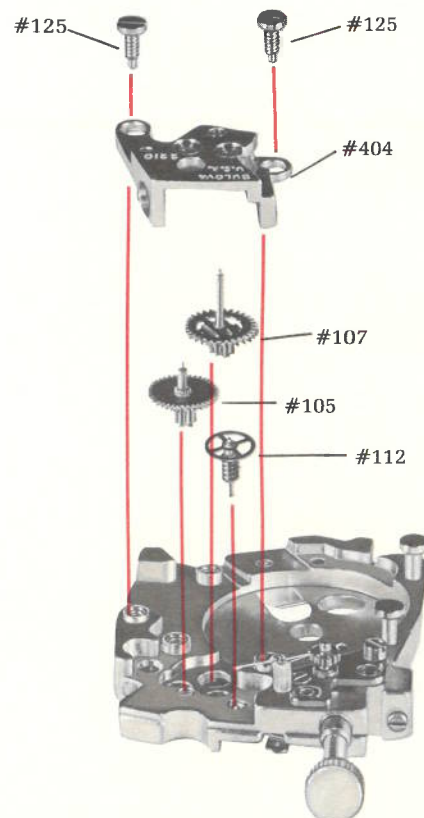

Fig. 67

Oil cap jewels and fourth wheel

1. Oil the two cap jewels in the pillar plate and the two cap jewels in the train bridge (V) Use oil sparingly. Do not flood jewels.

Note: Over-oiling of the index cap jewels will cause oil to run onto the index wheel necessitating re-cleaning of the index wheel.

2. Lubricate Fourth Wheel (#107) (M) between spacer and wheel. Use lubricant sparingly.

Caution: Do not rotate fourth wheel assembly unless lubricated.

3. Replace Fourth Wheel (#107), Third Wheel (#105) and Index Wheel (#112).
4. Replace Train Bridge (#404), centralize bridge and insert pivots of wheels. Be careful not to damage index wheel or Pawl Finger when replacing screws.

Note: Pay special attention to the cut-out area in the train bridge provided for the upper pivot of the Fourth Wheel

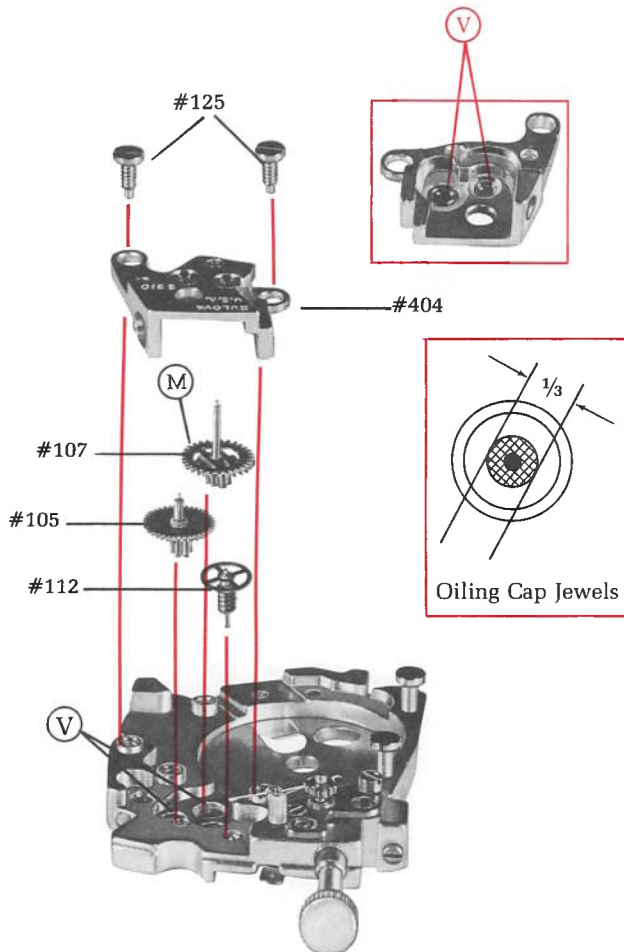

Fig. 68

Replace second wheel assembly

IMPORTANT: The second wheel must be replaced AFTER the train wheels and train bridge have been reassembled, NEVER before.

1. Replace Second Wheel (#103).
2. Replace Second Wheel Jewel Assembly (#325).
3. Replace Second Wheel Retainer Clip (#326).

Note: Both of the arms of the clip must enter the recess in the retainer assembly. Care should be taken not to distort the arms of the clip. Replace if distorted.

4. Oil second wheel jewel (V) on crown side. Use oil sparingly. Do not flood jewel.

Position the watch on end, insert lower pivot first. Use "One Touch" to hold the jewel assembly in place while inserting retainer clip.

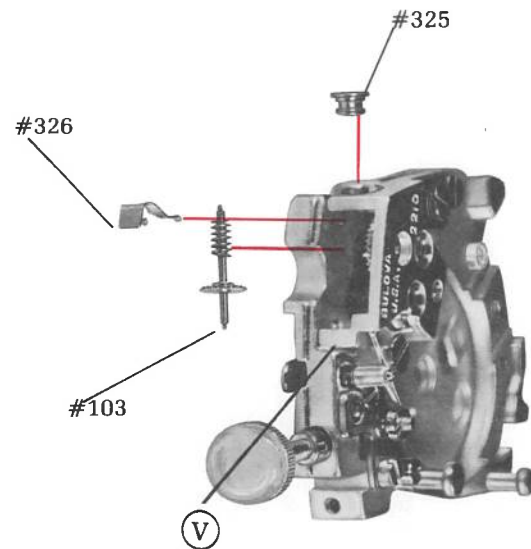

Fig. 69

(V) = Moebius OL219

(M) = Moebius OL207

(C) = Dow Corning Compound #11

Replace tuning fork

Caution:

- a) Care should be taken not to distort index finger.
 - b) Be sure to clear shock pins. Do not distort tines of fork.
1. Replace Tuning Fork (#716) and the two Screws (#183). These screws **must** be tight.
 2. Inspect clearance of tuning fork. The shock pins must be centered in the cut-outs of the tuning fork tines, and the fork must be centered between the pillar plate and the "heads" of the shock pins.

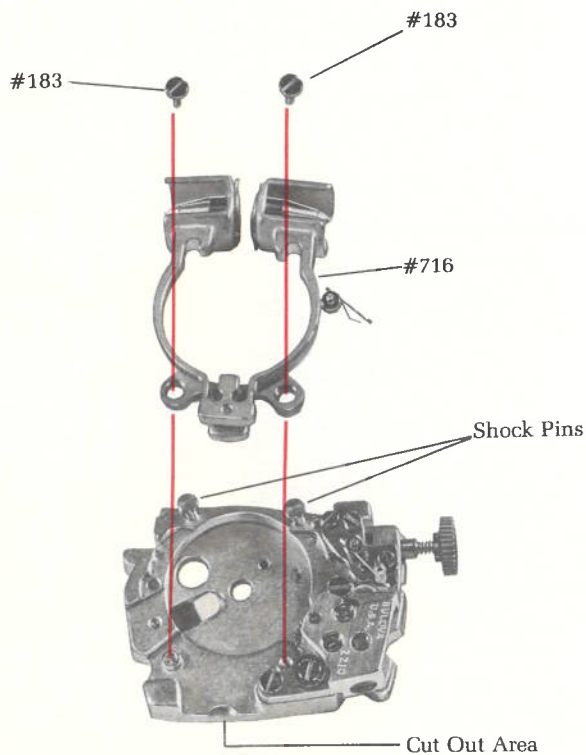

Fig. 70

Replace Coil Assemblies

Caution: Make sure that the magnets of the tuning fork are perfectly free of foreign matter.

1. Replace Component Coil Assembly (#712) and Coil Form Screw (#151). To align, press against surface of pillar plate and tighten screw.
2. Replace Cell Coil Assembly (#715) and Coil Form Screw (#151). To align, press against surface of pillar plate and tighten screw.
3. Tighten Lead Strap Screw (#304A). Be careful not to slip and cut the fine wires near the screw head.
4. Inspect alignment of coils (Pg. 30).

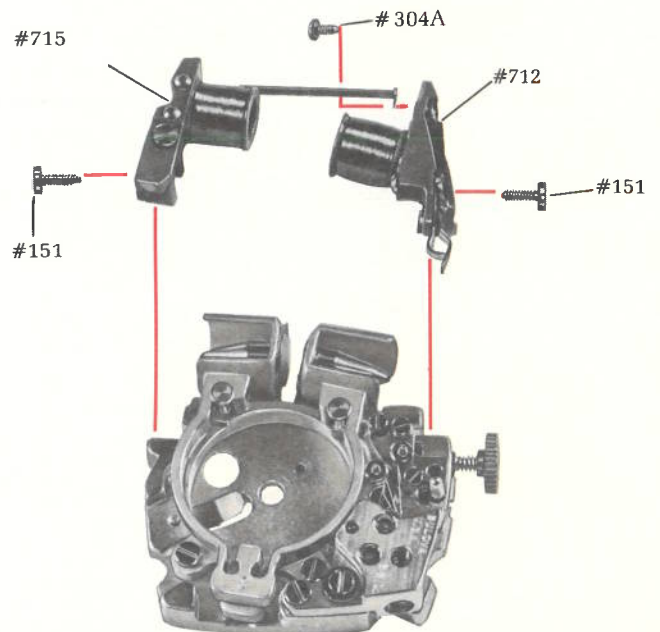

Fig. 71

Check Coil Clearance

1. With the "dial side down", inspect and note the amount of clearance between the tuning fork and the component coil.
2. TURN WATCH OVER
3. With the "dial side up", inspect and note the amount of clearance between the tuning fork and the component coil on this side.
4. The distance on both sides should be equal. At most, the ratio must not be more than 2:1 (two-to-one).
5. If correction is required, loosen the coil form screw and re-position the coil to its correct alignment. **Apply gentle pressure in proper direction while tightening screw securely.**
6. Perform the same inspection for the Cell Coil and correct if necessary.

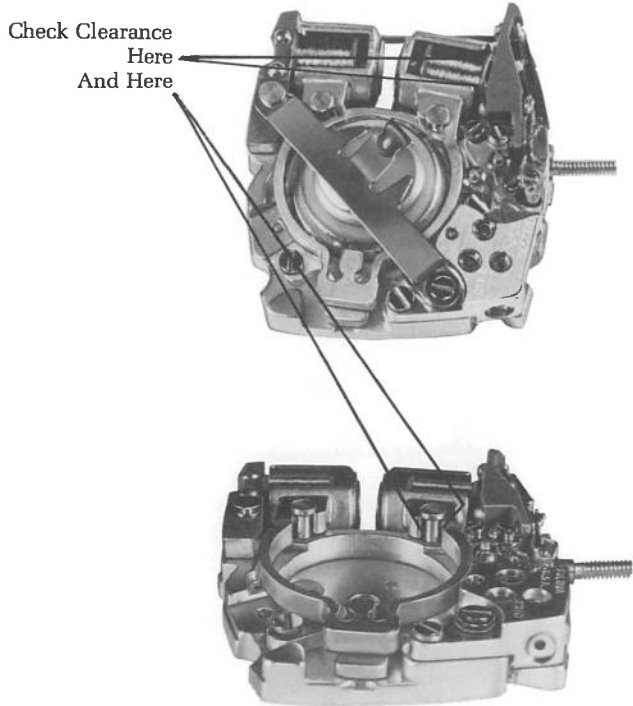

Fig. 72

Lubricate Train and Setting Mechanism

BRIDGE SIDE

1. Oil fourth wheel (V) upper pivot jewel.
2. Oil second wheel jewel (V) in jewel assembly.

DIAL SIDE

3. Oil lower fourth wheel jewel (V) located in yoke.

Note: Use oil sparingly. Do not flood jewels.

4. Lubricate setting mechanism (M).
5. Lubricate minute wheel post and setting wheel post (M). Use lubricant sparingly.
6. Lubricate Stem (M).

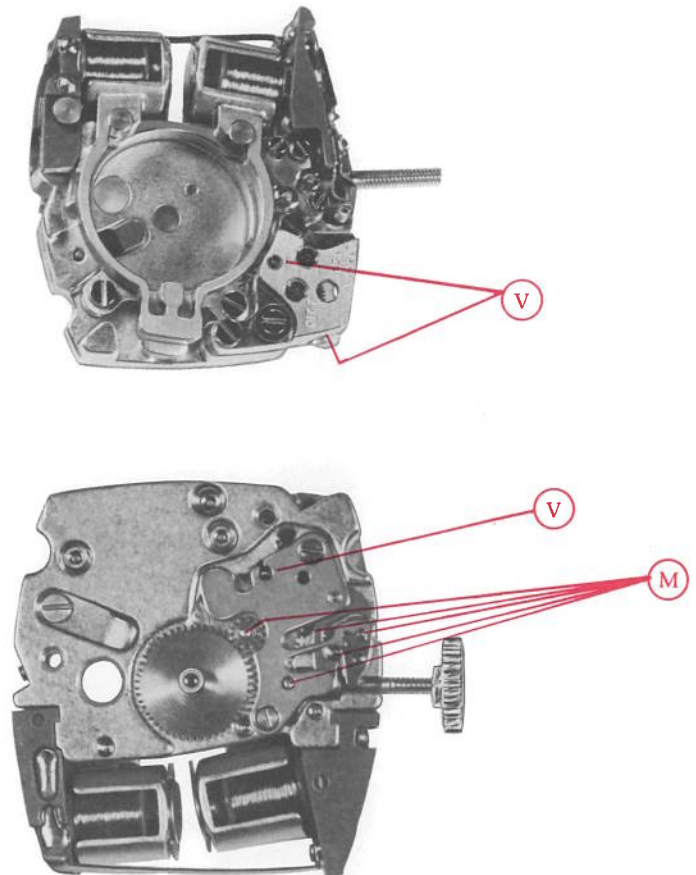

Fig. 73

(V) = Moebius OL219

(M) = Moebius OL207

(C) = Down Corning Compound #11

Pre-test Tuning Fork and Coil Assemblies

Attach the alligator clips of Test Set to movement to confirm that tuning fork and coil assemblies are working. The Test Set should read below seven (7) microamperes in the "Read Microamperes" position.

Phasing

Refer to Page 21 thru Page 23

Replace Dial and Hands

1. Loosen the two Dial Screws (#148).
2. Lubricate cannon pinion post, (C) use Dow Corning Compound #11.
3. Replace dial and hands. See page 32 if dial was not removed as a sub-assembly.

Note: When replacing as a sub-assembly, the hands should be placed at the 12 o'clock position to assist with proper alignment. Rotate the crown slightly to assist in the engagement of the dial train. "One Touch" or similar substance will be of assistance in keeping the hands on the "12 o'clock" marker.

4. Tighten the two Dial Screws (#148) and check to be certain that the dial is flush with the pillar plate.
5. **Check that there is clearance between the lead strap and the dial. Bend lead strap if necessary.**

Note: The Series 221 is manufactured with a dial washer of special design. If replacement is necessary, use only Genuine Material.

Check Phasing and Regulation

In order to confirm that the dialing operation did not disturb the phasing adjustment, check:

1. That the index wheel rotates in the "Low Amplitude" position.
2. That the meter reading is below seven (7) microamperes in the "Read Microamperes" position.
3. That the tuning fork is properly regulated.

Note: On Men's Model watches, the phasing check can be performed with the movement in the bezel of the case.

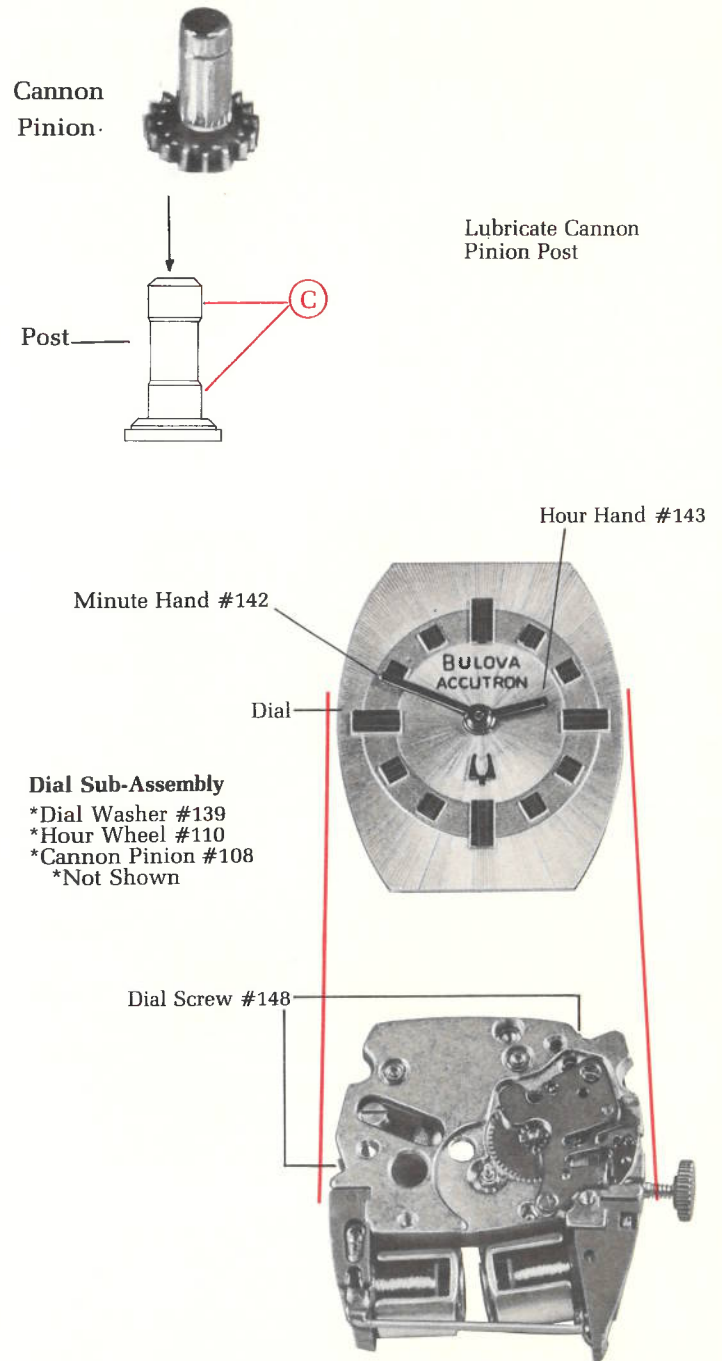

Fig. 74

SECTION VI — ADDITIONAL MAINTENANCE DISASSEMBLY AND REASSEMBLY

Lubricate Cannon
Pinion Post

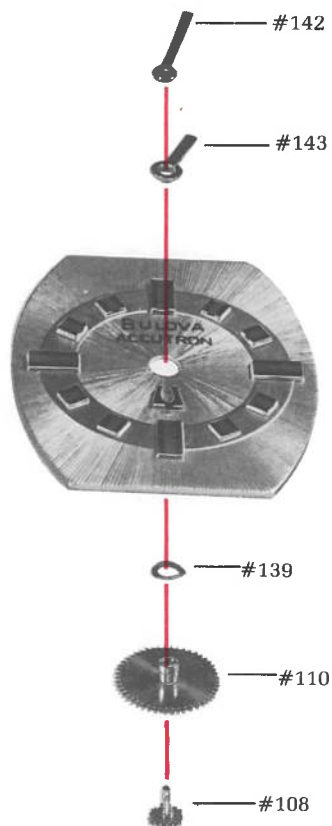
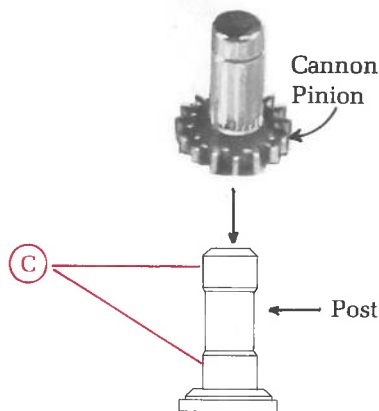

Fig. 75

Dial Assembly

1. Remove Hour Hand (#143) and Minute Hand (#142), using hand remover.
2. Loosen the two Dial Screws (#148) two (2) full turns.
3. Remove dial.
4. Tighten the two Dial Screws (#148).
5. Remove Dial Washer (#139).
6. Remove Hour Wheel (#110).
7. Remove Cannon Pinion (#108).

To Reassemble

1. Loosen the two Dial Screws (#148) two (2) full turns.
2. Lubricate cannon pinion post, (C) use Dow Corning Compound #11
3. Replace Cannon Pinion (#108).
4. Replace Hour Wheel (#110).
5. Replace Dial Washer (#139).
6. Replace dial. Check to be certain that dial is flush with pillar plate.
7. Tighten the two Dial Screws (#148).
8. Replace Hour Hand (#143). For proper fit, hour hand should be slightly above flush of Hour Wheel.
9. Replace Minute Hand (#142).

Note: The Series 221 is manufactured with a dial washer of special design. If replacement is necessary, use only Genuine Material. The dial washer must be 100% free of sharp bends.

Setting Mechanism

1. Remove the two Yoke Screws (#309).
2. Remove Yoke (#203).
3. Remove Minute Wheel (#111).
4. Remove Setting Wheel (#119).
5. Remove Clutch Lever (#204).
6. Remove Setting Lever Screw (#209).
7. Remove Setting Lever (#205), Stem (#176), and Clutch Wheel (#207).
8. Remove Ground Plate Screw (#315).
9. Remove Ground Plate (#212).

To Reassemble

1. Replace Setting Lever (#205) and Setting Lever Screw (#209).
2. Lubricate stem square and pilot (M) . Use lubricant sparingly.
3. Check clutch wheel teeth.
4. Replace Clutch Wheel (#207) and Stem (#176).
5. Lubricate minute wheel post and setting wheel post (M) . Use lubricant sparingly.
6. Replace Minute Wheel (#111) and Setting Wheel (#119).

Note: Chamfered side of setting wheel faces pillar plate.

7. Replace Clutch Lever (#204). Lubricate groove of clutch wheel sparingly (M) .
8. Replace Yoke (#203) and the two Yoke Screws (#309).
9. Lubricate yoke (M) .
10. Replace Ground Plate (#212) and its Screw (#315). Check that ground plate is properly centered in plate opening.

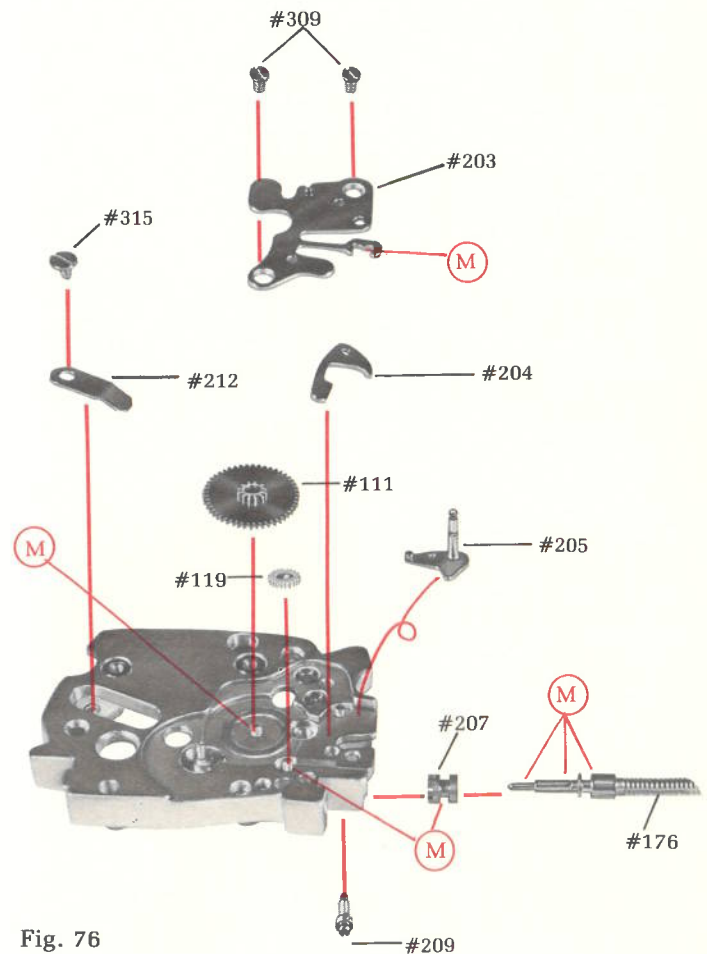

Fig. 76

(V) = Moebius OL219

(M) = Moebius OL207

(C) = Down Corning Compound #11

Pawl Bridge Assembly

1. Remove Pawl Bridge Lock Screw (#181).
2. Remove Pawl Bridge Pivot Screw (#184).
3. Remove Pawl Bridge Sub-Assembly (#180A) and Pawl Bridge Cam (#182). The cam is not threaded and will come out with the bridge.

Note: Care should be taken not to distort the pawl finger.

To Reassemble

1. Slide Pawl Bridge Cam (#182) into cut-out in Pawl Bridge (#180A). Replace Pawl Bridge Assembly.
2. Replace Pawl Bridge Pivot Screw (#184) and Pawl Bridge Lock Screw (#181).

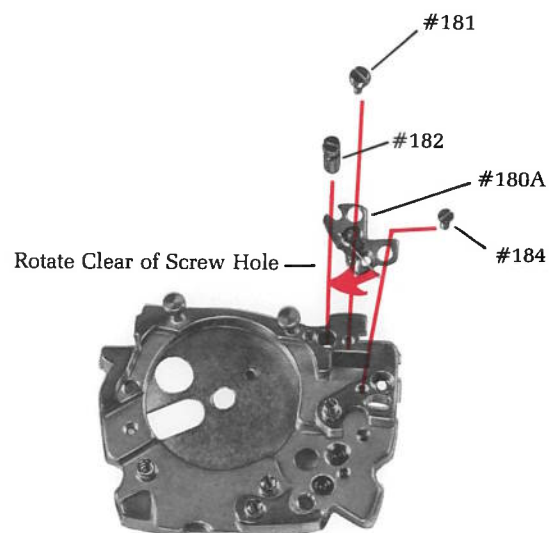

Fig. 77

SECTION VII — CHECKING THE CASED MOVEMENT

The series 221 movement has been designed to have vertical freedom when cased. The Cell Strap should be applying pressure on the movement to keep the dial in contact with the bezel (Fig. 78). At no time should the movement be restricted to a point where it is not free to move. Binding will cause an erratic timekeeper due to distortion of the movement assembly.

To Check Vertical Freedom

Figs. 79 & 80 show the necessary test procedures to check for vertical freedom.

1. Pull crown to "setting position."
2. Push the crown upwards (direction "A", Fig. 79), and look for downward movement of the dial "B", Fig. 79.
3. Push the crown downward (direction "C", Fig. 80), and look for downward movement of the dial "D", Fig. 80.







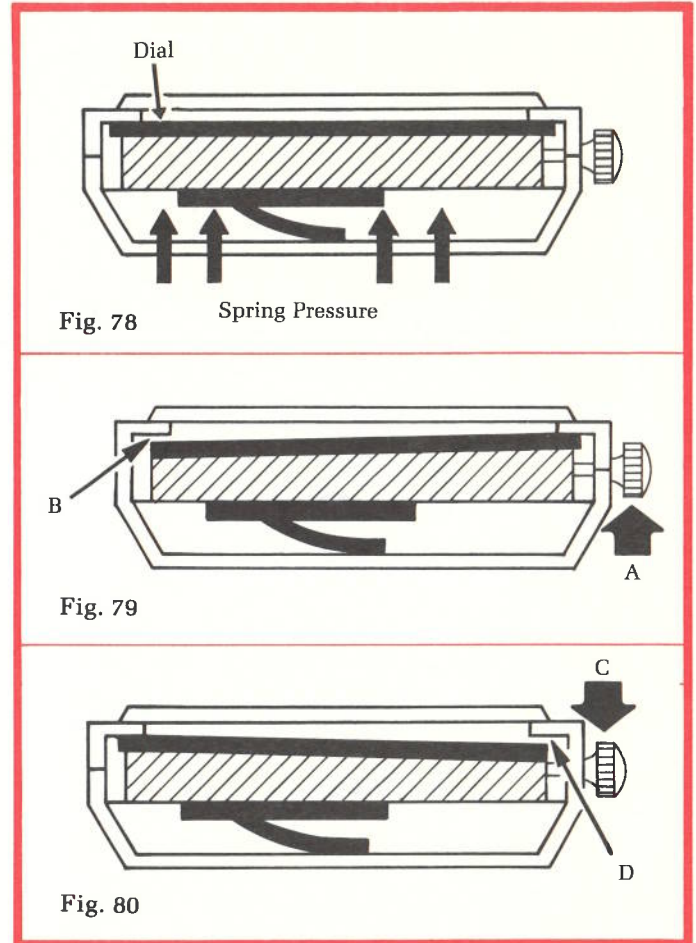







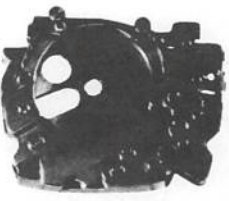

































The preceding checks confirm that the movement and dial are being pushed against the case bezel **by the Cell Strap**. Should there be no downward motion of the dial (direction "B" and "D"), then the movement is not free and the case back must be adjusted. Proceed as follows:

Check the general condition of the case back and bezel. Remove any dents or dimples causing distortion. The case may have been distorted because of engraving or dented by an accident or bumping during wear. Correct these if present.

Caution: Under no circumstances should the case back or bezel be bent or tampered with if there was no distortion present to begin with.



SECTION VII — PARTS LIST

 103 Second Wheel	 119 Setting Wheel	 159 U&L Index Wheel Jewel	 203 Yoke	 304A Lead Strap Screw	
 105 Third Wheel	 125 Train Bridge Screw	 162 Power Cell	 204 Clutch Lever	 306 Cell Strap Screw	
 107 Fourth Wheel	 139L Dial Washer (Lady's)	 176 Setting Stem	 205 Setting Lever	 309 Yoke Screw	 712 Component Coil Assembly
 108L Cannon Pinion (Lady's)	 139M Dial Washer (Man's)	 180A Pawl Brg Sub Assembly	 207 Clutch Wheel	 315 Ground Screw	 715 Cell Coil Ass'y
 108M Cannon Pinion (Man's)	 141 Cell Strap	 181 Pawl Bridge Lock Screw	 209 Setting Lever Screw	 325 Jewel Retainer Assembly	 716 Tuning Fork Assembly
 110L Hour Wheel (Lady's)	 142 Minute Hand	 182 Pawl Bridge Cam	 212 Ground Plate	 326 Retaining Clip	
 110M Hour Wheel (Man's)	 143 Hour Hand	 183 Tuning Fork Screw	 230 Index Finger Assembly	 404 Train Bridge	<p>The following material is ordered by the number stamped INSIDE the case back.</p> <p>Bezels Backs Gaskets Crystals Crowns</p>
 111 Minute Wheel	 148 Dial Screw	 184 Pawl brg Pivot Screw	 231 Pawl Finger Assembly	 610 Insulator	
 112 Index Wheel Assembly	 151 Coil Form Screw	 188 U&L Fourth Wheel Jewel	 286R* XXX (see footnote)	 2663	

*286R — 0.05 mm., 286R — 0.10 mm. Tuning Fork Shims — These were made for a very limited number of movements and are therefore not considered regular replacement parts.

PRINTED IN U.S.A.